

# CITY OF MERCER ISLAND

## COMMUNITY PLANNING & DEVELOPMENT

9611 SE 36TH STREET | MERCER ISLAND, WA 98040

PHONE: 206.275.7605 | [www.mercerisland.gov](http://www.mercerisland.gov)

Inspection Requests: Online: [www.MyBuildingPermit.com](http://www.MyBuildingPermit.com) VM: 206.275.7730



## SECTION A: SMALL PROJECT STORMWATER SITE PLAN/REPORT

### Narrative and Plan Submittal

**Instructions:** This is a template for a simplified Stormwater Report. This form or an equivalent must accompany your Building Permit Application if the answer is "Yes" to each statement below. If "No" is the answer to one or more of the statements below, a full Drainage Report is required and the project does not qualify for use of the Small Project Stormwater Site Plan/Report template.

Select "yes" or "no" for each statement below. Answer "yes" if the statement accurately describes your project.

Yes	No	Statement
		This project disturbs less than 1 acre and is not part of a larger common plan of development.
		This project converts less than 3/4 acre to lawn or landscape areas.
		This project will create, add, or replace (in any combination) 2,000 square feet or greater, but less than 5,000 square feet, of new plus replaced hard surface <b>OR</b> will have a land disturbing activity of 7,000 square feet or greater <b>OR</b> will result in a net increase of impervious surface of 500 square feet or greater.
		This project will not adversely impact a wetland, stream, water of the state, or change a natural drainage course.

### Basic Project Information

Project Name: \_\_\_\_\_

Site Address: \_\_\_\_\_

Total Lot Size: \_\_\_\_\_

Total Proposed Area to be Disturbed (including stockpile area): \_\_\_\_\_ sq ft

Total Volume of Proposed Cut and Fill: \_\_\_\_\_ sq ft

Total Proposed New Hard Surface Area: \_\_\_\_\_ sq ft

Total Proposed Replaced Hard Surface Area: \_\_\_\_\_ sq ft

Total Proposed Converted Pervious Surface Area  
(Native vegetation to lawn or landscape): \_\_\_\_\_ sq ft

Net Increase in Impervious Surface: \_\_\_\_\_ sq ft



# CITY OF MERCER ISLAND

## SECTION A: SMALL PROJECT STORMWATER SITE PLAN/REPORT

### Minimum Requirement #1 : Preparation of Stormwater Site Plan

Written Project Description:

Calculate new or replaced areas by surface type:

Lawn or Landscape Areas: _____ sq ft	Roof Area: _____ sq ft
Other Hard Surface Areas:	
Driveway: _____ sq ft    Patio: _____ sq ft    Sidewalk: _____ sq ft	
Parking Lot: _____ sq ft    Other: _____ sq ft	

Attach Drainage Plan

Drainage Plan shall include the following:

- Scaled drawing with slopes, lot lines, any public-right-of-way and any easements, location of each on-site stormwater management BMP selected above and the areas served by them, buildings, roads, parking lots, driveways, landscape features, and areas of disturbed soils to be amended.
- The scaled drawing must be suitable to serve as a recordable document that will be attached to the property deed for each lot that includes on-site BMPs. Document submittal must follow the “Standard Formatting Requirements for Recording Documents” per King County: [www.kingcounty.gov/depts/records-licensing/recorders-office/recording-documents.aspx](http://www.kingcounty.gov/depts/records-licensing/recorders-office/recording-documents.aspx)
- Identify design details and maintenance instructions for each on-site BMP, and attach them to this Small Project Stormwater Site Plan/Report.



# CITY OF MERCER ISLAND

## SECTION A: SMALL PROJECT STORMWATER SITE PLAN/REPORT

### Minimum Requirement #2 : Construction Stormwater Pollution Prevention

- Complete Section B of this submittal package: Construction Stormwater Pollution Prevention Plan Narrative (SWPPP)
- Attach construction SWPPP

### Minimum Requirement #3 : Source Control of Pollution

This section contains practices and procedures to reduce the release of pollutants. Provide a description of all known, available and reasonable source control BMPs that will be, or are anticipated to be, used at this location to prevent stormwater from coming into contact with pollutants. Additional BMPs are found in Volume IV of the 2014 Stormwater Management Manual for Western Washington (SWMMWW).

Check the BMPs you will use:

- BMP S411 for Landscaping and Lawn/ Vegetation Management  
Operational practices for sites with landscaping
- BMP S421 for Parking and Storage of Vehicles.  
Public and commercial parking lots can be sources of suspended solids, metals, or toxic hydrocarbons such oils and greases.
- BMP S433 for Pools, Spas, Hot Tubs, Fountains  
Discharge from pools, hot tubs, and fountains can degrade ambient water quality. Routine maintenance activities generate a variety of wastes. Direct disposal of these waters to drainage system and waters of the state are not permitted without prior treatment and approval.
- Other BMPs found in Volume IV of SWMMWW applicable to project:

- No source control BMPs are applicable for this project.



# CITY OF MERCER ISLAND

## SECTION A: SMALL PROJECT STORMWATER SITE PLAN/REPORT

### Minimum Requirement #4 : Preservation of Natural Drainage Systems

Natural drainage patterns shall be maintained and discharges from the project site shall occur at the natural location, to the maximum extent practicable. All outfalls require energy dissipation.

Choose the option below that best describes your project:

This site has existing drainage systems or outfalls. These items are shown on the Drainage Plan. Include the following items on the Drainage Plan:

- Pipe invert elevations, slopes, cover, and material
- Locations, grades, and direction of flow in ditches and swales, culverts, and pipes

Describe how these systems will be preserved:

This site does not have any existing drainage systems or outfalls.

Additional Comments:



# CITY OF MERCER ISLAND

## SECTION A: SMALL PROJECT STORMWATER SITE PLAN/REPORT

### Minimum Requirement #5 : On-site Stormwater Management

All projects meeting the thresholds for this Small Project Stormwater Report shall employ on-site stormwater management BMPs (See Small Project Stormwater Requirements Tip Sheet) to infiltrate, disperse, and retain stormwater runoff on-site to the extent feasible without causing flooding or erosion impacts.

#### List #1

For each category select the *first* feasible item on the list below. Document your justification for each infeasible BMP in Section C of this submittal package.

Check one option for each category below:



#### Lawn and Landscape Areas

- My project does not have *Lawn or Landscape* areas
- Post-construction soil quality and depth
- Post-construction soil quality and depth is infeasible (see Section C of this submittal package)



#### Roofs

- My project does not have *Roof* areas
- 1. Full dispersion or downspout full infiltration
- 2. Rain garden or bioretention
- 3. Downspout dispersion system
- 4. Perforated stub-out connections
- 5. On-site detention system or fee-in-lieu of on-site detention authorized by the City Engineer (applicable if options #1-4 are infeasible and drainage from the site will be discharged to a storm or surface water system that includes a watercourse or there is a capacity constraint in the system)
- 6. No Roof BMP (applicable if options #1-4 are infeasible and on-site detention is not required)

Measured Infiltration Rate: \_\_\_\_\_ in/ hr

If #5 or #6 is selected, briefly describe why no Roof BMP is feasible (include detailed information in Section C of this submittal package):



# CITY OF MERCER ISLAND

## SECTION A: SMALL PROJECT STORMWATER SITE PLAN/REPORT

### Minimum Requirement #5 : On-site Stormwater Management (cont.)



#### Other Hard Surfaces (such as driveway, sidewalk, parking lot, patio, etc.)

- My project does not have *Other Hard Surface* areas
- 1. Full dispersion
- 2. Permeable pavement, rain gardens, or bioretention
- 3. Sheet flow dispersion or concentrated flow dispersion
- 4. On-site detention system or fee-in-lieu of on-site detention authorized by the City Engineer (applicable if options #1-3 are infeasible and drainage from the site will be discharged to a storm or surface water system that includes a watercourse or there is a capacity constraint in the system)
- 5. No Other Hard Surface BMP (applicable if options #1-3 are infeasible and on-site detention is not required)

Measured Infiltration Rate: \_\_\_\_\_ in/ hr

If #4 or #5 is selected, briefly describe why no Other Hard Surface BMP is feasible (include detailed information in Section C of this submittal package):

### Flow Control Exempt List

Proceed with this list if your project discharges directly to Lake Washington or if findings from a downstream analysis confirm that the downstream system is free of capacity constraints for a minimum of ¼ mile and a maximum of 1 mile.

For flow control exempt discharges, the BMPs listed below for Roofs and Other Hard Surfaces do not need to be evaluated in priority order. You can select any BMP from the lists provided below and do not need to document infeasibility in Section C of this submittal package.

Check one option for each category below:



#### Lawn and Landscape Areas

- My project does not have *Lawn or Landscape* areas
- Post-construction soil quality and depth



# CITY OF MERCER ISLAND

## SECTION A: SMALL PROJECT STORMWATER SITE PLAN/REPORT

### Minimum Requirement #5 : On-site Stormwater Management (cont.)



#### Roofs

- My project does not have *Roof* areas
- Downspout full infiltration
- Downspout dispersion system
- Perforated stub-out connections
- Each item above is infeasible

If “Each item above is infeasible” is selected, briefly describe why no Roof BMP is feasible:



#### Other Hard Surfaces (such as driveway, sidewalk, parking lot, patio, etc.)

- My project does not have *Other Hard Surface* areas
- Sheet flow dispersion
- Concentrated flow dispersion
- Each item above is infeasible

If “Each item above is infeasible” is selected, briefly describe why no Other Hard Surface BMP is feasible:



# CITY OF MERCER ISLAND

## SECTION B: SMALL PROJECT CONSTRUCTION SWPPP NARRATIVE

### Instructions

This is a template for a simplified Construction Stormwater Pollution Prevention Plan (“Construction SWPPP”). If “No” is the answer to one or more of the statements on the first page of Section A of this submittal package, then a full Construction SWPPP is required and the project does not qualify for the use of the Small Project Construction SWPPP Narrative template. If the project is less than the thresholds on the first page of Section A of this submittal package, then Minimum Requirement #2 still applies, but this section (Section B) or a full construction SWPPP is not required. You should include your Construction SWPPP in your contract with your builder. A copy of the Construction SWPPP must be located at the construction site or within reasonable access to the site for construction and inspection personnel at all times.

### General Information on the Existing Site and Project

Describe the following in the Project Narrative box below (attach additional pages if necessary):

- Nature and purpose of the construction project
- Existing topography, vegetation, and drainage, and building structures
- Adjacent areas, including streams, lakes, wetlands, residential areas, and roads that might be affected by the construction project
- How upstream drainage areas may affect the site
- Downstream drainage leading from the site to the receiving body of water
- Areas on or adjacent to the site that are classified as critical areas
- Critical areas that receive runoff from the site up to one-quarter mile away
- Special requirements and provisions for working near or within critical areas
- Areas on the site that have potential erosion problems

Project Narrative:



# CITY OF MERCER ISLAND

## SECTION B: SMALL PROJECT CONSTRUCTION SWPPP NARRATIVE

### Construction SWPPP Drawings

Refer to the general Drawing Requirements in Stormwater Management Manual for Western Washington (SWMMWW) Volume I, Chapter 3.

### Vicinity Map

Provide a map with enough detail to identify the location of the construction site, adjacent roads, and receiving waters.

### Site Map

Include the following (where applicable):

- |  |   |
|--|---|
| <input type="checkbox"/> Legal description of the property boundaries or an illustration of property lines (including distances) on the drawings.          | <input type="checkbox"/> Final and interim grade contours as appropriate, drainage basins, and the direction of stormwater flow during and upon completion of construction. |
| <input type="checkbox"/> North arrow.  | <input type="checkbox"/> Areas of soil disturbance, including all areas affected by clearing, grading, and excavation.  |
| <input type="checkbox"/> Existing structures and roads.  | <input type="checkbox"/> Locations where stormwater will discharge to surface waters during and upon completion of construction.  |
| <input type="checkbox"/> Boundaries and identification of different soil types.  | <input type="checkbox"/> Existing unique or valuable vegetation and vegetation to be preserved.   |
| <input type="checkbox"/> Areas of potential erosion problems.  | <input type="checkbox"/> Cut-and-fill slopes indicating top and bottom of slope catch lines.  |
| <input type="checkbox"/> Any on-site and adjacent surface waters, critical areas, buffers, flood plain boundaries, and Shoreline Management boundaries.    | <input type="checkbox"/> Total cut-and-fill quantities and the method of disposal for excess material.  |
| <input type="checkbox"/> Existing contours and drainage basins and the direction of flow for the different drainage areas.                                 | <input type="checkbox"/> Stockpile; waste storage; and vehicle storage, maintenance, and washdown areas.  |
| <input type="checkbox"/> Where feasible, contours extend a minimum of 25 feet beyond property lines and extend sufficiently to depict existing conditions. |   |

### Temporary and Permanent BMPs

Include the following on site map (where applicable):

- |   |  |
|---|--|
| <input type="checkbox"/> Locations for temporary and permanent swales, interceptor trenches, or ditches.                                      | <input type="checkbox"/> Details for bypassing off-site runoff around disturbed areas.   |
| <input type="checkbox"/> Drainage pipes, ditches, or cut-off trenches associated with erosion and sediment control and stormwater management. | <input type="checkbox"/> Locations of temporary and permanent stormwater treatment and/or flow control best management practices (BMPs).   |
| <input type="checkbox"/> Temporary and permanent pipe inverts and minimum slopes and cover.   | <input type="checkbox"/> Details for all structural and nonstructural erosion and sediment control (ESC) BMPs (including, but not limited to, silt fences, construction entrances, sedimentation facilities, etc.) |
| <input type="checkbox"/> Grades, dimensions, and direction of flow in all ditches and swales, culverts, and pipes.                            | <input type="checkbox"/> Details for any construction-phase BMPs or techniques used for Low Impact Development (LID) BMP protection.   |
| <input type="checkbox"/> Locations and outlets of any dewatering systems.   |  |



# CITY OF MERCER ISLAND

## SECTION B: SMALL PROJECT CONSTRUCTION SWPPP NARRATIVE

### Element 1: Preserve Vegetation / Mark Clearing Limits

The goal of this element is to preserve native vegetation and to clearly show the limits of disturbance.

This element **does not** apply to my project because:

The site was cleared as part of clearing activity that is subject to an enforcement action and is re-vegetated. Restoration may be necessary to comply with Critical Area Regulations or NPDES requirements. Buffer Zones-BMP C102 may apply if Critical Areas exist on-site and buffer zones shall be protected.

Other Reason / Additional Comments:

If it **does** apply, describe the steps you will take and select the best management practices (BMPs) you will use:

The perimeter of the area to be cleared shall be marked prior to clearing operation with visible flagging, orange plastic barrier fencing and/or orange silt fencing as shown on the SWPPP site map. The total disturbed area shall be less than 7,000 square feet. Vehicles will only be allowed in the areas to be graded, so no compaction of the undeveloped areas will occur.

Additional Comments:

Check the BMPs you will use:

C101 Preserving Natural Vegetation

C102 Buffer Zones

C103 High Visibility Fence



# CITY OF MERCER ISLAND

## SECTION B: SMALL PROJECT CONSTRUCTION SWPPP NARRATIVE

### Element 2: Construction Access

The goal of this element is to provide a stabilized construction entrance/exit to prevent or reduce or sediment track out.

This element **does not** apply to my project because:

The driveway to the construction area already exists and will be used for construction access. All equipment and vehicles will be restricted to staying on that existing impervious surface.

Other Reason / Additional Comments:

If it **does** apply, describe the steps you will take and select the BMPs you will use:

A stabilized construction entrance will be installed prior to any vehicles entering the site, at the location shown on the SWPPP site map.

Additional Comments:

Check the BMPs you will use:

C105 Stabilized Construction Entrance / Exit

C106 Wheel Wash

C107 Construction Road / Parking Area Stabilization



# CITY OF MERCER ISLAND

## SECTION B: SMALL PROJECT CONSTRUCTION SWPPP NARRATIVE

### Element 3: Control Flow Rates

The goal of this element is to construct retention or detention facilities when necessary to protect properties and waterways downstream of development sites from erosion and turbid discharges.

This element **does not** apply to my project because:

Other Reason / Additional Comments:

If it **does** apply, describe the steps you will take and select the BMPs you will use:

Flow rates will be controlled by using SWPPP Element 4 sediment controls and BMP T5.13 Post-Construction Soil Quality and Depth if necessary.

Additional Comments:



# CITY OF MERCER ISLAND

## SECTION B: SMALL PROJECT CONSTRUCTION SWPPP NARRATIVE

### Element 4: Sediment Control

The goal of this element is to construct sediment control BMPs that minimize sediment discharges from the site.

This element **does not** apply to my project because:

The site has already been stabilized and re-vegetated.

Other Reason / Additional Comments:

If it **does** apply, describe the steps you will take and select the BMPs you will use:

Sediment control BMPs shall be placed at the locations shown on the SWPPP site map

Additional Comments:

Check the BMPs you will use:

C231 Brush Barrier

C233 Silt Fence

C235 Wattles

C232 Gravel Filter Berm

C234 Vegetated Strip



# CITY OF MERCER ISLAND

## SECTION B: SMALL PROJECT CONSTRUCTION SWPPP NARRATIVE

### Element 5: Stabilize Soils

The goal of this element is to stabilize exposed and unworked soils by implementing erosion control BMPs.

This element **does not** apply to my project because:

Other Reason / Additional Comments:

If it **does** apply, describe the steps you will take and select the BMPs you will use:

Exposed soils shall be worked during the week until they have been stabilized. Soil stockpiles will be located within the disturbed area shown on the SWPPP site map. Soil excavated for the foundation will be backfilled against the foundation and graded to drain away from the building. No soils shall remain exposed and unworked for more than 7 days from May 1 to September 30 or more than 2 days from October 1 to April 30. Once the disturbed landscape areas are graded, the grass areas will be amended using BMP T5.13 Post-Construction Soil Quality and Depth. All stockpiles will be covered with plastic or burlap if left unworked.

Additional Comments:

Check the BMPs you will use:

- C120 Temporary & Permanent Seeding
- C122 Nets & Blankets
- C124 Sodding
- C131 Gradient Terraces
- C235 Wattles
- C121 Mulching
- C123 Plastic Covering
- C125 Topsoil / Composting
- C140 Dust Control



# CITY OF MERCER ISLAND

## SECTION B: SMALL PROJECT CONSTRUCTION SWPPP NARRATIVE

### Element 6: Protect Slopes

The goal of this element is to design and construct cut-and-fill slopes in a manner to minimize erosion.

This element **does not** apply to my project because:

No cut slopes over 4 feet high or slopes steeper than 2 feet horizontal to 1 foot vertical, and no fill slopes over 4 feet high will exceed 3 feet horizontal to 1 foot vertical. Therefore, there is no requirement for additional engineered slope protection.

Other Reason / Additional Comments:

If it **does** apply, describe the steps you will take and select the BMPs you will use:

Additional Comments:

Check the BMPs you will use:

- |   |   |   |
|---|---|---|
| <input type="checkbox"/> C120 Temporary & Permanent Seeding | <input type="checkbox"/> C205 Subsurface Drains | <input type="checkbox"/> C207 Check Dams  |
| <input type="checkbox"/> C204 Pipe Slope Drains             | <input type="checkbox"/> C206 Level Spreader    | <input type="checkbox"/> C208 Triangular Silt Dike (Geotextile-Encased Check Dam) |



# CITY OF MERCER ISLAND

## SECTION B: SMALL PROJECT CONSTRUCTION SWPPP NARRATIVE

### Element 7: Protect Permanent Drain Inlets

The goal of this element is to protect storm drain inlets during construction to prevent stormwater runoff from entering the conveyance system without being filtered or treated.

This element **does not** apply to my project because:

- The site has open ditches in the right-of-way or private road right-of-way.
- There are no catch basins on or near the site.
- Other Reason / Additional Comments:

If it **does** apply, describe the steps you will take and select the BMPs you will use:

- Catch basins on the site or immediately off site in the right-of-way are shown on the SWPPP site map. Storm drain inlet protection shall be installed.

Additional Comments:

Check the BMPs you will use:

- C220 Storm Drain Inlet Protection



# CITY OF MERCER ISLAND

## SECTION B: SMALL PROJECT CONSTRUCTION SWPPP NARRATIVE

### Element 8: Stabilize Channels and Outlets

The goal of this element is to design, construct, and stabilize on-site conveyance channels to prevent erosion from entering existing stormwater outfalls and conveyance systems.

This element **does not** apply to my project because:

Construction will occur during the dry weather. No storm drainage channels or ditches shall be constructed either temporary or permanent. A small swale shall be graded to convey yard drainage around the structure using a shallow slope; it shall be seeded after grading and stabilized.

Other Reason / Additional Comments:

If it **does** apply, describe the steps you will take and select the BMPs you will use:

A wattle shall be placed at the end of the swale to prevent erosion at the outlet of the swale.

Additional Comments:

Check the BMPs you will use:

C202 Channel Lining     C207 Check Dams     C209 Outlet Protection     C235 Wattles



# CITY OF MERCER ISLAND

## SECTION B: SMALL PROJECT CONSTRUCTION SWPPP NARRATIVE

### Element 9: Control Pollutants

The goal of this element is to design, install, implement and maintain BMPs to minimize the discharge of pollutants from material storage areas, fuel handling, equipment cleaning, management of waste materials, etc.

This element **does not** apply to my project because:

Other Reason / Additional Comments:

If it **does** apply, describe the steps you will take and select the BMPs you will use:

Any and all pollutants, chemicals, liquid products and other materials that have the potential to pose a threat to human health or the environment will be covered, contained, and protected from vandalism. All such products shall be kept under cover in a secure location on-site. Concrete handling shall follow BMP C151.

Additional Comments:

Check the BMPs you will use:

C151 Concrete Handling

C152 Sawcutting and Surfacing Pollution Prevention

C153 Material Delivery, Storage, and Containment

C154 Concrete Washout Area



# CITY OF MERCER ISLAND

## SECTION B: SMALL PROJECT CONSTRUCTION SWPPP NARRATIVE

### Element 10: Control De-watering

The goal of this element is to handle turbid or contaminated dewatering water separately from stormwater.

This element **does not** apply to my project because:

No dewatering of the site is anticipated.

Other Reason / Additional Comments:

If it **does** apply, describe the steps you will take and select the BMPs you will use:

Additional Comments:

Check the BMPs you will use:

C203 Water Bars

C236 Vegetated Filtration

C206 Level Spreader



# CITY OF MERCER ISLAND

## SECTION B: SMALL PROJECT CONSTRUCTION SWPPP NARRATIVE

### Element 11: Maintain Best Management Practices

The goal of this element is to maintain and repair all temporary and permanent erosion and sediment control BMPs to assure continued performance.

*Describe the steps you will take:*

- Best Management Practices or BMPs shall be inspected and maintained during construction and removed within 30 days after the City Inspector or Engineer determines that the site is stabilized, provided that they may be removed when they are no longer needed.

### Element 12: Manage the Project

The goal of this element is to ensure that the construction SWPPP is properly coordinated and that all BMPs are deployed at the proper time to achieve full compliance with City regulations throughout the project.

If it **does** apply, describe the steps you will take and select the BMPs you will use:

The Construction SWPPP will be implemented at all times. The applicable erosion control BMPs will be implemented in the following sequence:

- 1. Mark clearing limits
- 2. Install stabilized construction entrance
- 3. Install protection for existing drainage systems and permanent drain inlets
- 4. Establish staging areas for storage and handling polluted material and BMPs
- 5. Install sediment control BMPs
- 6. Grade and install stabilization measures for disturbed areas
- 7. Maintain BMPs until site stabilization, at which time they may be removed

Additional Comments:



# CITY OF MERCER ISLAND

## SECTION B: SMALL PROJECT CONSTRUCTION SWPPP NARRATIVE

### Element 13: Protect Low Impact Development BMPs

The goal of this element is to protect on-site stormwater management BMPs (also known as “Low Impact Development BMPs”) from siltation and compaction during construction. On-site stormwater management BMPs used for runoff from roofs and other hard surfaces include: full dispersion, roof downspout full infiltration or dispersion systems, perforated stubout connections, rain gardens, bioretention systems, permeable pavement, sheetflow dispersion, and concentrated flow dispersion. Methods for protecting on-site stormwater management BMPs include sequencing the construction to install these BMPs at the latter part of the construction grading operations, excluding equipment from the BMPs and the associated areas, and using the erosion and sedimentation control BMPs listed below.

*Describe the construction sequencing you will use:*

Additional Comments:

*Select the BMPs you will use:*

- |   |   |   |
|---|---|---|
| <input type="checkbox"/> C102 Buffer Zone | <input type="checkbox"/> C103 High Visibility Fence | <input type="checkbox"/> C231 Brush Barrier |
| <input type="checkbox"/> C233 Silt Fence  | <input type="checkbox"/> C234 Vegetated Strip       |   |



# CITY OF MERCER ISLAND

## SECTION C: INFEASIBILITY CRITERIA

### Minimum Requirement #5 (On-Site Stormwater Management)

The following tables summarize infeasibility criteria that can be used to justify not using various on-site stormwater management best management practices (BMPs) for consideration for Minimum Requirement #5. This information is also included under the detailed descriptions of each BMP in the 2014 Stormwater Management Manual for Western Washington (Stormwater Manual), but is provided here in this worksheet for additional clarity and efficiency. Where any inconsistencies or lack of clarity exists, the requirements in the main text of the Stormwater Manual shall be applied. If a project is limited by one or more of the infeasibility criteria specified below, but an applicant is interested in implementing a specific BMP, a functionally equivalent design may be submitted to the City for review and approval. Evaluate the feasibility of the BMPs in priority order based on List #1 or #2 (Small Project Stormwater Requirements Tip Sheet and Stormwater Manual). Select the first BMP that is considered feasible for each surface type. Document the infeasibility (narrative description and rationale) for each BMP that was not selected. Only one infeasibility criterion needs to be selected for a BMP before evaluating the next BMP on the list. Attach additional pages for supporting information if necessary.

Note: If your project discharges directly to Lake Washington (flow control exempt) or a downstream analysis confirms that the downstream system is free of capacity constraints for a minimum of ¼ mile and a maximum of 1 mile, then you do not need to complete this worksheet, but should still refer to the infeasibility criteria when selecting BMPs.

Lawn and Landscaped Areas		
BMP and Applicable Lists	Infeasibility Criteria	Infeasibility Description and Rationale for Each BMP Not Selected
Post-construction Soil Quality and Depth List #1 and #2	<input type="checkbox"/> Siting and design criteria provided in BMP T5.13 ( <b>Stormwater Manual</b> Volume V, Section 5.3) cannot be achieved.  <input type="checkbox"/> Lawn and landscape area is on till slopes greater than 33 percent.	
Roofs		
BMP and Applicable Lists	Infeasibility Criteria	Infeasibility Description and Rationale for Each BMP Not Selected
Full Dispersion List #1 and #2	<input type="checkbox"/> Site setbacks and design criteria provided in BMP T5.30 ( <b>Stormwater Manual</b> Volume V, Section 5.3) cannot be achieved.  <input type="checkbox"/> A 65 to 10 ratio of forested or native vegetation area to impervious area cannot be achieved.  <input type="checkbox"/> A minimum forested or native vegetation flowpath length of 100 feet (25 feet for sheet flow from a non-native pervious surface) cannot be achieved.	
Downspout Full Infiltration List #1 and #2	<input type="checkbox"/> Evaluation of infiltration is not required per the Infiltration Infeasibility Map due to steep slopes, erosion hazards, or landslide hazards.  <input type="checkbox"/> Site setbacks and design criteria provided in BMP T5.10A ( <b>Stormwater Manual</b> Volume III, Section 3.1.1) cannot be achieved.  <input type="checkbox"/> The lot(s) or site does not have out-wash or loam soils.  <input type="checkbox"/> There is not at least 3 feet or more of permeable soil from the proposed final grade to the seasonal high groundwater table or other impermeable layer.  <input type="checkbox"/> There is not at least 1 foot or more of permeable soil from the proposed bottom of the infiltration system to the seasonal high groundwater table or other impermeable layer.	



# CITY OF MERCER ISLAND

## SECTION C: INFEASIBILITY CRITERIA

Roofs (cont.)		
BMP and Applicable Lists	Infeasibility Criteria	Infeasibility Description and Rationale for Each BMP Not Selected
<p>Bioretention or Rain Gardens</p> <p>List #1 (both) and List #2 (bioretention only)</p>	<p><i>Note: Criteria with setback distances are as measured from the bottom edge of the bioretention soil mix.</i></p> <p>Citation of any of the following infeasibility criteria must be based on an evaluation of site-specific conditions and a written recommendation from an appropriate licensed professional (e.g., engineer, geologist, hydrogeologist):</p> <ul style="list-style-type: none"> <li><input type="checkbox"/> Where professional geotechnical evaluation recommends infiltration not be used due to reasonable concerns about erosion, slope failure, or down-gradient flooding.</li> <li><input type="checkbox"/> Within an area whose ground water drains into an erosion hazard, or landslide hazard area.</li> <li><input type="checkbox"/> Where the only area available for siting would threaten the safety or reliability of pre-existing underground utilities, pre-existing underground storage tanks, pre-existing structures, or pre-existing road or parking lot surfaces.</li> <li><input type="checkbox"/> Where the only area available for siting does not allow for a safe overflow pathway to stormwater drainage system or private storm sewer system.</li> <li><input type="checkbox"/> Where there is a lack of usable space for bioretention areas at re-development sites, or where there is insufficient space within the existing public right-of-way on public road projects.</li> <li><input type="checkbox"/> Where infiltrating water would threaten existing below grade basements.</li> <li><input type="checkbox"/> Where infiltrating water would threaten shoreline structures such as bulkheads.</li> </ul> <p>The following criteria can be cited as reasons for infeasibility without further justification (though some require professional services to make the observation):</p> <ul style="list-style-type: none"> <li><input type="checkbox"/> Evaluation of infiltration is not required per the Infiltration Infeasibility Map due to steep slopes, erosion hazards, or landslide hazards</li> <li><input type="checkbox"/> Within setback provided for BMP T7.30 (<b>Stormwater Manual</b> Volume V, Section 7.4)</li> <li><input type="checkbox"/> Where they are not compatible with surrounding drainage system as determined by the city (e.g., project drains to an existing stormwater collection system whose elevation or location precludes connection to a properly functioning bioretention area).</li> </ul>	



# CITY OF MERCER ISLAND

## SECTION C: INFEASIBILITY CRITERIA

Roofs (cont.)		
BMP and Applicable Lists	Infeasibility Criteria	Infeasibility Description and Rationale for Each BMP Not Selected
Bioretention or Rain Gardens (cont.)	<p>The following criteria can be cited as reasons for infeasibility without further justification (though some require professional services to make the observation):</p> <ul style="list-style-type: none"> <li><input type="checkbox"/> Where land for bioretention is within an erosion hazard, or landslide hazard area (as defined by MICC 19.07.060).</li> <li><input type="checkbox"/> Where the site cannot be reasonably designed to locate bioretention areas on slopes less than 8 percent. <b>NO SPACE BETWEEN STRUCTURES AND EXISTING TREE ROOTS.</b></li> <li><input type="checkbox"/> Within 50 feet from the top of slopes that are greater than 20 percent and over 10 feet of vertical relief.</li> <li><input type="checkbox"/> For properties with known soil or groundwater contamination (typically federal Superfund sites or state cleanup sites under the Model Toxics Control Act [MTCA]):               <ul style="list-style-type: none"> <li>• Within 100 feet of an area known to have deep soil contamination.</li> <li>• Where groundwater modeling indicates infiltration will likely increase or change the direction of the migration of pollutants in the groundwater.</li> <li>• Wherever surface soils have been found to be contaminated unless those soils are removed within 10 horizontal feet from the infiltration area.</li> <li>• Any area where these facilities are prohibited by an approved cleanup plan under the state MTCA or Federal Superfund Law, or an environmental covenant under Chapter 64.70 RCW.</li> </ul> </li> <li><input type="checkbox"/> Within 100 feet of a closed or active landfill.</li> <li><input type="checkbox"/> Within 10 feet of an underground storage tank and connecting underground pipes when the capacity of the tank and pipe system is 1,100 gallons or less. As used in these criteria, an underground storage tank means any tank used to store petroleum products, chemicals, or liquid hazardous wastes of which 10 percent or more of the storage volume (including volume in the connecting piping system) is beneath the ground surface.</li> <li><input type="checkbox"/> Within 100 feet of an underground storage tank and connecting underground pipes when the capacity of the tank and pipe system is greater than 1,100 gallons.</li> </ul>	



# CITY OF MERCER ISLAND

## SECTION C: INFEASIBILITY CRITERIA

Roofs (cont.)		
BMP and Applicable Lists	Infeasibility Criteria	Infeasibility Description and Rationale for Each BMP Not Selected
Bioretention or Rain Gardens (cont.)	<p>The following criteria can be cited as reasons for infeasibility without further justification (though some require professional services to make the observation):</p> <ul style="list-style-type: none"> <li><input type="checkbox"/> Where field testing indicates potential bioretention/rain garden sites have a measured (a.k.a., initial) native soil saturated hydraulic conductivity less than 0.30 inches per hour. A small-scale or large-scale PIT in accordance with <b>Stormwater Manual</b> Volume III, Section 3.3.6 (or an alternative small scale test specified by the City) shall be used to demonstrate infeasibility of bioretention areas. If the measured native soil infiltration rate is less than 0.30 in/hour, bioretention/rain garden BMPs are not required to be evaluated as an option in List #1 or List #2. In these slow draining soils, a bioretention area with an underdrain may be used to treat pollution-generating surfaces to help meet Minimum Requirement #6, Runoff Treatment. If the underdrain is elevated within a base course of gravel, it will also provide some modest flow reduction benefit that will help achieve Minimum Requirement #7.</li> <li><input type="checkbox"/> Where the minimum vertical separation of 3 feet to the seasonal high groundwater elevation or other impermeable layer would not be achieved below bioretention that would serve a drainage area that exceeds the following thresholds (and cannot reasonably be broken down into amounts smaller than indicated):             <ul style="list-style-type: none"> <li>o 5,000 square feet of pollution-generating impervious surface (PGIS)</li> <li>o 10,000 square feet of impervious area</li> <li>o 0.75 acres of lawn and landscape.</li> </ul> </li> <li><input type="checkbox"/> Where the minimum vertical separation of 1 foot to the seasonal high groundwater or other impermeable layer would not be achieved below bioretention that would serve a drainage area less than the above thresholds.</li> <li><input type="checkbox"/> Within 100 feet of a drinking water well, or a spring used for drinking water supply.</li> <li><input type="checkbox"/> Within 10 feet of small on-site sewage disposal drainfield, including reserve areas, and grey water reuse systems. For setbacks from a "large on-site sewage disposal system," see Chapter 246-272B WAC.</li> </ul>	



# CITY OF MERCER ISLAND

## SECTION C: INFEASIBILITY CRITERIA

Roofs (cont.)		
BMP and Applicable Lists	Infeasibility Criteria	Infeasibility Description and Rationale for Each BMP Not Selected
<p>Downspout Dispersion Systems</p> <p>List #1 and #2</p>	<ul style="list-style-type: none"> <li><input type="checkbox"/> Site setbacks and design criteria provided in BMP T5.10B (<b>Stormwater Manual</b> Volume III, Section 3.1.2) cannot be achieved.</li> <li><input type="checkbox"/> For splash blocks, a vegetated flowpath at least 50 feet in length from the downspout to the downstream property line, structure, stream, wetland, slope over 15 percent, or other impervious surface is not feasible.</li> <li><input type="checkbox"/> For trenches, a vegetated flowpath of at least 25 feet in between the outlet of the trench and any property line, structure, stream, wetland, or impervious surface is not feasible. A vegetated flowpath of at least 50 feet between the outlet of the trench and any slope steeper than 15 percent is not feasible.</li> </ul>	
<p>Perforated Stub-Out Connections</p> <p>List #1 and #2</p>	<ul style="list-style-type: none"> <li><input type="checkbox"/> Evaluation of infiltration is not required per the Infiltration Infeasibility Map due to steep slopes, erosion hazards, or landslide hazards</li> <li><input type="checkbox"/> For sites with septic systems, the only location available for the perforated portion of the pipe is located up-gradient of the drainfield primary and reserve areas. This requirement can be waived if site topography will clearly prohibit flows from intersecting the drainfield or where site conditions (soil permeability, distance between systems, etc.) indicate that this is unnecessary.</li> <li><input type="checkbox"/> Site setbacks and design criteria provided in BMP T5.10C (<b>Stormwater Manual</b> Volume III, Section 3.1.3) cannot be achieved.</li> <li><input type="checkbox"/> There is not at least 1 foot of permeable soil from the proposed bottom (final grade) of the perforated stub-out connection trench to the highest estimated groundwater table or other impermeable layer.</li> <li><input type="checkbox"/> The only location available for the perforated stub-out connection is under impervious or heavily compacted soils.</li> </ul>	
<p>On-site Detention</p> <p>List #1 and #2</p>	<ul style="list-style-type: none"> <li><input type="checkbox"/> Project discharges directly to Lake Washington.</li> <li><input type="checkbox"/> Findings from a 1/4 mile downstream analysis confirm that the downstream system is free of capacity constraints.</li> <li><input type="checkbox"/> Site setbacks and design criteria provided in the <b>Stormwater Manual</b> (Volume III, Section 3.2.2) cannot be achieved.</li> </ul>	



# CITY OF MERCER ISLAND

## SECTION C: INFEASIBILITY CRITERIA

Other Hard Surfaces		
BMP and Applicable Lists	Infeasibility Criteria	Infeasibility Description and Rationale for Each BMP Not Selected
Full Dispersion List #1 and #2	<ul style="list-style-type: none"> <li><input type="checkbox"/> Site setbacks and design criteria provided in BMP T5.30 (<b>Stormwater Manual</b> Volume V, Section 5.3) cannot be achieved.</li> <li><input type="checkbox"/> A 65 to 10 ratio of forested or native vegetation area to impervious area cannot be achieved.</li> <li><input type="checkbox"/> A minimum forested or native vegetation flowpath length of 100 feet (25 feet for sheet flow from a non-native pervious surface) cannot be achieved.</li> </ul>	
Permeable Pavement List #1 and #2	<p>Citation of any of the following infeasibility criteria must be based on an evaluation of site-specific conditions and a written recommendation from an appropriate licensed professional (e.g., engineer, geologist, hydrogeologist):</p> <ul style="list-style-type: none"> <li><input type="checkbox"/> Where professional geotechnical evaluation recommends infiltration not be used due to reasonable concerns about erosion, slope failure, or downgradient flooding.</li> <li><input type="checkbox"/> Within an area whose ground water drains into an erosion hazard, or landslide hazard area.</li> <li><input type="checkbox"/> Where infiltrating and ponded water below the new permeable pavement area would compromise adjacent impervious pavements.</li> <li><input type="checkbox"/> Where infiltrating water below a new permeable pavement area would threaten existing below grade basements.</li> <li><input type="checkbox"/> Where infiltrating water would threaten shoreline structures such as bulkheads.</li> <li><input type="checkbox"/> Down slope of steep, erosion prone areas that are likely to deliver sediment.</li> <li><input type="checkbox"/> Where fill soils are used that can become unstable when saturated.</li> <li><input type="checkbox"/> Excessively steep slopes where water within the aggregate base layer or at the subgrade surface cannot be controlled by detention structures and may cause erosion and structural failure, or where surface runoff velocities may preclude adequate infiltration at the pavement surface.</li> <li><input type="checkbox"/> Where permeable pavements cannot provide sufficient strength to support heavy loads at industrial facilities such as ports.</li> <li><input type="checkbox"/> Where installation of permeable pavement would threaten the safety or reliability of pre-existing underground utilities, pre-existing underground storage tanks, or pre-existing road subgrades.</li> </ul>	



# CITY OF MERCER ISLAND

## SECTION C: INFEASIBILITY CRITERIA

Other Hard Surfaces (cont.)		
BMP and Applicable Lists	Infeasibility Criteria	Infeasibility Description and Rationale for Each BMP Not Selected
Permeable Pavement (cont.)	<p>The following criteria can be cited as reasons for infeasibility without further justification (though some require professional services to make the observation):</p> <ul style="list-style-type: none"> <li><input type="checkbox"/> Evaluation of infiltration is not required per the Infiltration Infeasibility Map due to steep slopes, erosion hazards, or landslide hazards</li> <li><input type="checkbox"/> Within an area designated as an erosion hazard, or landslide hazard.</li> <li><input type="checkbox"/> Within 50 feet from the top of slopes that are greater than 20 percent.</li> <li><input type="checkbox"/> For properties with known soil or groundwater contamination (typically federal Superfund sites or state cleanup sites under MTCA):               <ul style="list-style-type: none"> <li>• Within 100 feet of an area known to have deep soil contamination.</li> <li>• Where groundwater modeling indicates infiltration will likely increase or change the direction of the migration of pollutants in the groundwater.</li> <li>• Wherever surface soils have been found to be contaminated unless those soils are removed within 10 horizontal feet from the infiltration area.</li> <li>• Any area where these facilities are prohibited by an approved cleanup plan under the state MTCA or Federal Superfund Law, or an environmental covenant under Chapter 64.70 RCW.</li> </ul> </li> <li><input type="checkbox"/> Within 100 feet of a closed or active landfill.</li> <li><input type="checkbox"/> Within 100 feet of a drinking water well, or a spring used for drinking water supply, if the pavement is a pollution-generating surface.</li> <li><input type="checkbox"/> Within 10 feet of a small on-site sewage disposal drainfield, including reserve areas, and grey water reuse systems. For setbacks from a “large on-site sewage disposal system,” see Chapter 246-272B WAC.</li> <li><input type="checkbox"/> Within 10 feet of any underground storage tank and connecting underground pipes, regardless of tank size. As used in these criteria, an underground storage tank means any tank used to store petroleum products, chemicals, or liquid hazardous wastes of which 10 percent or more of the storage volume (including volume in the connecting piping system) is beneath the ground surface.</li> <li><input type="checkbox"/> At multi-level parking garages, and over culverts and bridges.</li> <li><input type="checkbox"/> Where the site design cannot avoid putting pavement in areas likely to have long-term excessive sediment deposition after construction (e.g., construction and landscaping material yards).</li> </ul>	



# CITY OF MERCER ISLAND

## SECTION C: INFEASIBILITY CRITERIA

Other Hard Surfaces (cont.)		
BMP and Applicable Lists	Infeasibility Criteria	Infeasibility Description and Rationale for Each BMP Not Selected
Permeable Pavement (cont.)	<p>The following criteria can be cited as reasons for infeasibility without further justification (though some require professional services to make the observation):</p> <ul style="list-style-type: none"> <li><input type="checkbox"/> Where the site cannot reasonably be designed to have:               <ul style="list-style-type: none"> <li>• Porous asphalt surface &lt; 5% slope</li> <li>• Pervious concrete surface &lt; 10% slope</li> <li>• Permeable interlocking concrete pavement surface &lt; 12% slope</li> <li>• Grid systems &lt; 6-12% slope (check with manufacturer and local supplier to confirm maximum slope)</li> </ul> </li> <li><input type="checkbox"/> Where the subgrade soils below a pollution-generating permeable pavement (e.g., road or parking lot) do not meet the soil suitability criteria for providing treatment. See soil suitability criteria for treatment in the <b>Stormwater Manual</b> Volume III, Section 3.3.7. Note: In these instances, the city may approve installation of a 6 inch sand filter layer meeting city specifications for treatment as a condition of construction.</li> <li><input type="checkbox"/> Where underlying soils are unsuitable for supporting traffic loads when saturated. Soils meeting a California Bearing Ratio of 5 percent are considered suitable for residential access roads.</li> <li><input type="checkbox"/> Where replacing existing impervious surfaces unless the existing surface is a non-pollution generating surface over an outwash soil with a saturated hydraulic conductivity of 4 inches per hour or greater.</li> <li><input type="checkbox"/> Where appropriate field testing indicates soils have a measured (a.k.a., initial) subgrade soil saturated hydraulic conductivity less than 0.3 inches per hour. Only small-scale PIT or large-scale PIT methods in accordance with <b>Stormwater Manual</b> Volume III, Section 3.3.6 (or an alternative small scale test specified by the City) shall be used to evaluate infeasibility of permeable pavement areas. (Note: In these instances, unless other infeasibility restrictions apply, roads and parking lots may be built with an underdrain, preferably elevated within the base course, if flow control benefits are desired.)</li> <li><input type="checkbox"/> Roads that receive more than very low traffic volumes, and areas having more than very low truck traffic. Roads with a projected average daily traffic volume of 400 vehicles or less are very low volume roads (AASHTO 2001) (U.S. Department of Transportation, 2013). Areas with very low truck traffic volumes are roads and other areas not subject to through truck traffic but may receive up to weekly use by utility trucks (e.g., garbage, recycling), daily school bus use, and multiple daily use by pick-up trucks, mail/parcel delivery trucks, and maintenance vehicles. (Note: This infeasibility criterion does not extend to sidewalks and other non-traffic bearing surfaces associated with the collector or arterial).</li> </ul>	



# CITY OF MERCER ISLAND

## SECTION C: INFEASIBILITY CRITERIA

Other Hard Surfaces (cont.)		
BMP and Applicable Lists	Infeasibility Criteria	Infeasibility Description and Rationale for Each BMP Not Selected
Permeable Pavement (cont.)	<p>The following criteria can be cited as reasons for infeasibility without further justification (though some require professional services to make the observation):</p> <ul style="list-style-type: none"> <li><input type="checkbox"/> At sites defined as “high-use sites” (refer to the Glossary in the <b>Stormwater Manual</b> Volume I).</li> <li><input type="checkbox"/> In areas with “industrial activity” as identified in 40 CFR 122.26(b)(14).</li> <li><input type="checkbox"/> Where the risk of concentrated pollutant spills is more likely such as gas stations, truck stops, and industrial chemical storage sites.</li> <li><input type="checkbox"/> Where routine, heavy applications of sand occur in frequent snow zones to maintain traction during weeks of snow and ice accumulation.</li> <li><input type="checkbox"/> Where the seasonal high groundwater or an underlying impermeable/low permeable layer would create saturated conditions within 1 foot of the bottom of the lowest gravel base course.</li> </ul>	
Bioretention or Rain Gardens  List #1 (both) and List #2 (bioretention only)	<p><i>Note: Criteria with setback distances are as measured from the bottom edge of the bioretention soil mix.</i></p> <p>Citation of any of the following infeasibility criteria must be based on an evaluation of site-specific conditions and a written recommendation from an appropriate licensed professional (e.g., engineer, geologist, hydrogeologist):</p> <ul style="list-style-type: none"> <li><input type="checkbox"/> Where professional geotechnical evaluation recommends infiltration not be used due to reasonable concerns about erosion, slope failure, or down-gradient flooding.</li> <li><input type="checkbox"/> Within an area whose ground water drains into an erosion hazard, or landslide hazard area.</li> <li><input type="checkbox"/> Where the only area available for siting would threaten the safety or reliability of pre-existing underground utilities, pre-existing underground storage tanks, pre-existing structures, or pre-existing road or parking lot surfaces.</li> <li><input type="checkbox"/> Where the only area available for siting does not allow for a safe overflow pathway to stormwater drainage system or private storm sewer system.</li> <li><input type="checkbox"/> Where there is a lack of usable space for bioretention areas at re-development sites, or where there is insufficient space within the existing public right-of-way on public road projects.</li> <li><input type="checkbox"/> Where infiltrating water would threaten existing below grade basements.</li> <li><input type="checkbox"/> Where infiltrating water would threaten shoreline structures such as bulkheads.</li> </ul>	



# CITY OF MERCER ISLAND

## SECTION C: INFEASIBILITY CRITERIA

Other Hard Surfaces (cont.)		
BMP and Applicable Lists	Infeasibility Criteria	Infeasibility Description and Rationale for Each BMP Not Selected
Bioretention or Rain Gardens (cont.)	<p>The following criteria can be cited as reasons for infeasibility without further justification (though some require professional services to make the observation):</p> <ul style="list-style-type: none"> <li><input type="checkbox"/> Where evaluation of infiltration is not required per the Infiltration Infeasibility Map due to steep slopes, erosion hazards, or landslide hazards.</li> <li><input type="checkbox"/> Within setback provided for BMP T7.30 (<b>Stormwater Manual</b> Volume V, Section 7.4)</li> <li><input type="checkbox"/> Where they are not compatible with surrounding drainage system as determined by the city (e.g., project drains to an existing stormwater collection system whose elevation or location precludes connection to a properly functioning bioretention area).</li> <li><input type="checkbox"/> Where land for bioretention is within an erosion hazard, or landslide hazard area (as defined by MICC 19.07.060).</li> <li><input type="checkbox"/> Where the site cannot be reasonably designed to locate bioretention areas on slopes less than 8 percent.</li> <li><input type="checkbox"/> Within 50 feet from the top of slopes that are greater than 20 percent and over 10 feet of vertical relief.</li> <li><input type="checkbox"/> For properties with known soil or groundwater contamination (typically federal Superfund sites or state cleanup sites under the Model Toxics Control Act [MTCA]):               <ul style="list-style-type: none"> <li>• Within 100 feet of an area known to have deep soil contamination.</li> <li>• Where groundwater modeling indicates infiltration will likely increase or change the direction of the migration of pollutants in the groundwater.</li> <li>• Wherever surface soils have been found to be contaminated unless those soils are removed within 10 horizontal feet from the infiltration area.</li> <li>• Any area where these facilities are prohibited by an approved cleanup plan under the state MTCA or Federal Superfund Law, or an environmental covenant under Chapter 64.70 RCW.</li> </ul> </li> <li><input type="checkbox"/> Within 100 feet of a closed or active landfill.</li> <li><input type="checkbox"/> Within 10 feet of an underground storage tank and connecting underground pipes when the capacity of the tank and pipe system is 1,100 gallons or less. As used in these criteria, an underground storage tank means any tank used to store petroleum products, chemicals, or liquid hazardous wastes of which 10 percent or more of the storage volume (including volume in the connecting piping system) is beneath the ground surface.</li> </ul>	



# CITY OF MERCER ISLAND

## SECTION C: INFEASIBILITY CRITERIA

Other Hard Surfaces (cont.)		
BMP and Applicable Lists	Infeasibility Criteria	Infeasibility Description and Rationale for Each BMP Not Selected
Bioretention or Rain Gardens (cont.)	<p>The following criteria can be cited as reasons for infeasibility without further justification (though some require professional services to make the observation):</p> <ul style="list-style-type: none"> <li><input type="checkbox"/> Within 100 feet of an underground storage tank and connecting underground pipes when the capacity of the tank and pipe system is greater than 1,100 gallons.</li>   <li><input type="checkbox"/> Where field testing indicates potential bioretention/rain garden sites have a measured (a.k.a., initial) native soil saturated hydraulic conductivity less than 0.30 inches per hour. A small-scale or large-scale PIT in accordance with <b>Stormwater Manual</b> Volume III, Section 3.3.6 (or an alternative small scale test specified by the City) shall be used to demonstrate infeasibility of bioretention areas. If the measured native soil infiltration rate is less than 0.30 in/hour, bioretention/rain garden BMPs are not required to be evaluated as an option in List #1 or List #2. In these slow draining soils, a bioretention area with an underdrain may be used to treat pollution-generating surfaces to help meet Minimum Requirement #6, Runoff Treatment. If the underdrain is elevated within a base course of gravel, it will also provide some modest flow reduction benefit that will help achieve Minimum Requirement #7.</li>   <li><input type="checkbox"/> Where the minimum vertical separation of 3 feet to the seasonal high groundwater elevation or other impermeable layer would not be achieved below bioretention that would serve a drainage area that exceeds the following thresholds (and cannot reasonably be broken down into amounts smaller than indicated): <ul style="list-style-type: none"> <li>o 5,000 square feet of pollution-generating impervious surface (PGIS)</li> <li>o 10,000 square feet of impervious area</li> <li>o 0.75 acres of lawn and landscape.</li> </ul> </li>   <li><input type="checkbox"/> Where the minimum vertical separation of 1 foot to the seasonal high groundwater or other impermeable layer would not be achieved below bioretention that would serve a drainage area less than the above thresholds</li>   <li><input type="checkbox"/> Within 100 feet of a drinking water well, or a spring used for drinking water supply.</li>   <li><input type="checkbox"/> Within 10 feet of small on-site sewage disposal drainfield, including reserve areas, and grey water reuse systems. For setbacks from a "large on-site sewage disposal system," see Chapter 246-272B WAC.</li> </ul>	



# CITY OF MERCER ISLAND

## SECTION C: INFEASIBILITY CRITERIA

Other Hard Surfaces (cont.)		
BMP and Applicable Lists	Infeasibility Criteria	Infeasibility Description and Rationale for Each BMP Not Selected
Sheet Flow Dispersion List #1 and #2	<ul style="list-style-type: none"> <li><input type="checkbox"/> Site setbacks and design criteria provided in BMP T5.12 (<b>Stormwater Manual</b> Volume V, Section 5.3) cannot be achieved.</li> <li><input type="checkbox"/> Positive drainage for sheet flow runoff cannot be achieved.</li> <li><input type="checkbox"/> Area to be dispersed (e.g., driveway, patio) cannot be graded to have less than a 15 percent slope.</li> <li><input type="checkbox"/> For flat to moderately sloped areas, at least a 10 foot-wide vegetation buffer for dispersion of the adjacent 20 feet of contributing surface cannot be achieved. For variably sloped areas, at least a 25 foot vegetated flowpath between berms cannot be achieved.</li> </ul>	
Concentrated Flow Dispersion List #1 and #2	<ul style="list-style-type: none"> <li><input type="checkbox"/> Site setbacks and design criteria provided in BMP T5.11 (<b>Stormwater Manual</b> Volume V, Section 5.3) cannot be achieved.</li> <li><input type="checkbox"/> A minimum 3 foot length of rock pad and 50 foot flowpath OR a dispersion trench and 25 foot flowpath for every 700 square feet of drainage area followed with applicable setbacks cannot be achieved.</li> <li><input type="checkbox"/> More than 700 square feet drainage area drains to any dispersion device.</li> </ul>	
On-site Detention List #1 and #2	<ul style="list-style-type: none"> <li><input type="checkbox"/> Project discharges directly to Lake Washington.</li> <li><input type="checkbox"/> Findings from a 1/4 mile downstream analysis confirm that the downstream system is free of capacity constraints.</li> <li><input type="checkbox"/> Site setbacks and design criteria provided in the <b>Stormwater Manual</b> (Volume III, Section 3.2.2) cannot be achieved.</li> </ul>	



# CITY OF MERCER ISLAND

## SECTION D: POST-CONSTRUCTION SOIL MANAGEMENT

### Attachments Required *(Check off required items that are attached)*

<input type="checkbox"/> Site Plan showing, to scale:	<input type="checkbox"/> Areas of undisturbed native vegetation (no amendment required) <input type="checkbox"/> New planting beds (amendment required) <input type="checkbox"/> New turf areas (amendment required) <input type="checkbox"/> Type of soil improvement proposed for each area
<input type="checkbox"/> Soil test results (required if proposing custom amendment rates)	
<input type="checkbox"/> Product test results for proposed amendments	

### Total Amendment / Topsoil / Mulch for All Areas

Calculate the quantities needed for the entire site based on all of the areas identified on the Site Plan and the calculations on the following page(s):

Product	Total Quantity (CY)	Test Results
Product #1: _____	_____ CY	_____ % organic matter _____ C:N ratio "Stable"?    yes <input type="checkbox"/> no <input type="checkbox"/>
Product #2: _____	_____ CY	_____ % organic matter _____ C:N ratio "Stable"?    yes <input type="checkbox"/> no <input type="checkbox"/>
Product #3: _____	_____ CY	_____ % organic matter _____ C:N ratio "Stable"?    yes <input type="checkbox"/> no <input type="checkbox"/>

CY = cubic yards, C:N = Carbon:Nitrogen



# CITY OF MERCER ISLAND

## SECTION D: POST-CONSTRUCTION SOIL MANAGEMENT

### Amendment / Topsoil / Mulch by Area

For each identified area on your Site Plan, provide the following information: (Use additional sheets if necessary)

Area # \_\_\_\_\_ (should match identified Area # on Site Plan)

Planting type:  Turf  Undisturbed native vegetation  
 Planting Beds  Other: \_\_\_\_\_

### Pre-Approved Amendment Method

<input type="checkbox"/> Amend with compost	Turf: _____ SF x 5.4 CY ÷ 1,000 SF = _____ CY Planting beds: _____ SF x 9.3 CY ÷ 1,000 SF = _____ CY Total Quantity = _____ CY Scarification depth: 8 inches	Product: _____
<input type="checkbox"/> Stockpile and amend	Turf: _____ SF x 5.4 CY ÷ 1,000 SF = _____ CY Planting beds: _____ SF x 9.3 CY ÷ 1,000 SF = _____ CY Total Quantity = _____ CY Scarification depth: 8 inches	Product: _____
<input type="checkbox"/> Topsoil import	Turf: _____ SF x 18.6 CY ÷ 1,000 SF = _____ CY Planting beds: _____ SF x 18.6 CY ÷ 1,000 SF = _____ CY Total Quantity = _____ CY Scarification depth: 6 inches	Product: _____

### Custom Amendment

<input type="checkbox"/> Amend with compost	Attach information on bulk density, percent organic matter, moisture content, C:N ratio, and heavy metals analysis to support custom amendment rate and scarification depth. Total Quantity = _____ CY Scarification depth: _____ inches	Product: _____
<input type="checkbox"/> Stockpile and amend	Attach information on bulk density, percent organic matter, moisture content, C:N ratio, and heavy metals analysis to support custom amendment rate and scarification depth. Total Quantity = _____ CY Scarification depth: _____ inches	Product: _____

### Mulch

<input type="checkbox"/> Amend with compost	Planting beds: _____ SF x 12.4 CY ÷ 1,000 SF = _____ CY Total Quantity = _____ CY	Product: _____
<input type="checkbox"/> Stockpile and amend	Planting beds: _____ SF x 12.4 CY ÷ 1,000 SF = _____ CY Total Quantity = _____ CY	Product: _____
<input type="checkbox"/> Topsoil import	Planting beds: _____ SF x 12.4 CY ÷ 1,000 SF = _____ CY Total Quantity = _____ CY	Product: _____

CY = cubic yards, C:N = Carbon:Nitrogen



# CITY OF MERCER ISLAND

## SECTION E: SIGNATURE PAGE

### Project Engineer's Certification for Section B

For Stormwater Site Plans with engineered elements, the Construction SWPPP is stamped by a professional engineer licensed in the State of Washington in civil engineering.

If required, attach a page with the project engineer's seal with the following statement:

*"I hereby state that this Construction Stormwater Pollution Prevention Plan for \_\_\_\_\_  
(name of project)  
has been prepared by me or under my supervision and meets the standard of care and expertise which is usual and customary in this community for professional engineers. I understand that the City of Mercer Island does not and will not assume liability for the sufficiency, suitability, or performance of Construction SWPPP BMPs prepared by me."*

### Applicant Signature for Full Stormwater Package (Sections A through D)

I have read and completed the Stormwater Submittal Package and know the information provided to be true and correct.

Print Applicant Name: \_\_\_\_\_

Applicant Signature: K. Radis E. Cali Date \_\_\_\_\_

area.

### Figure III-3.1.8 Perforated Stub-Out Connection

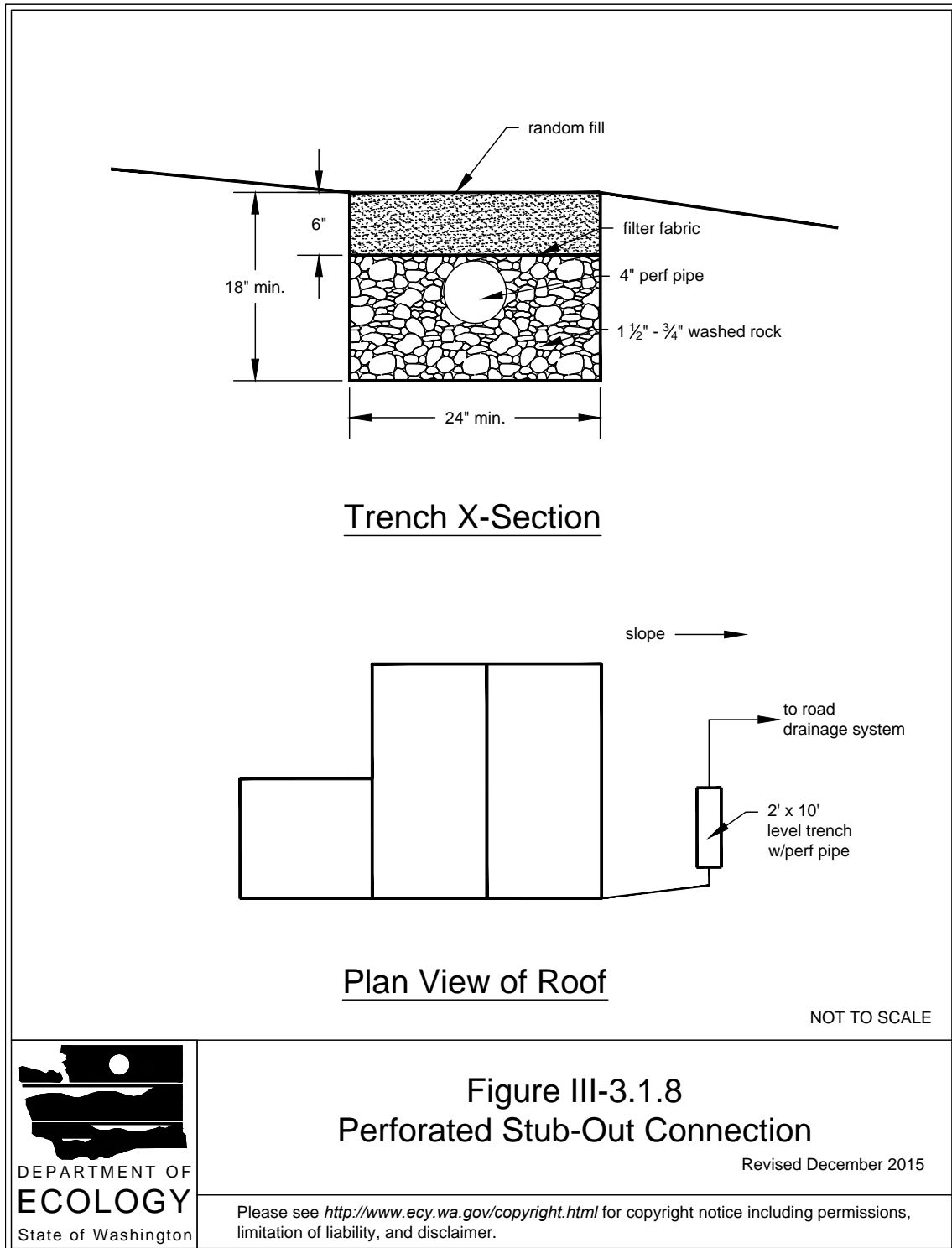
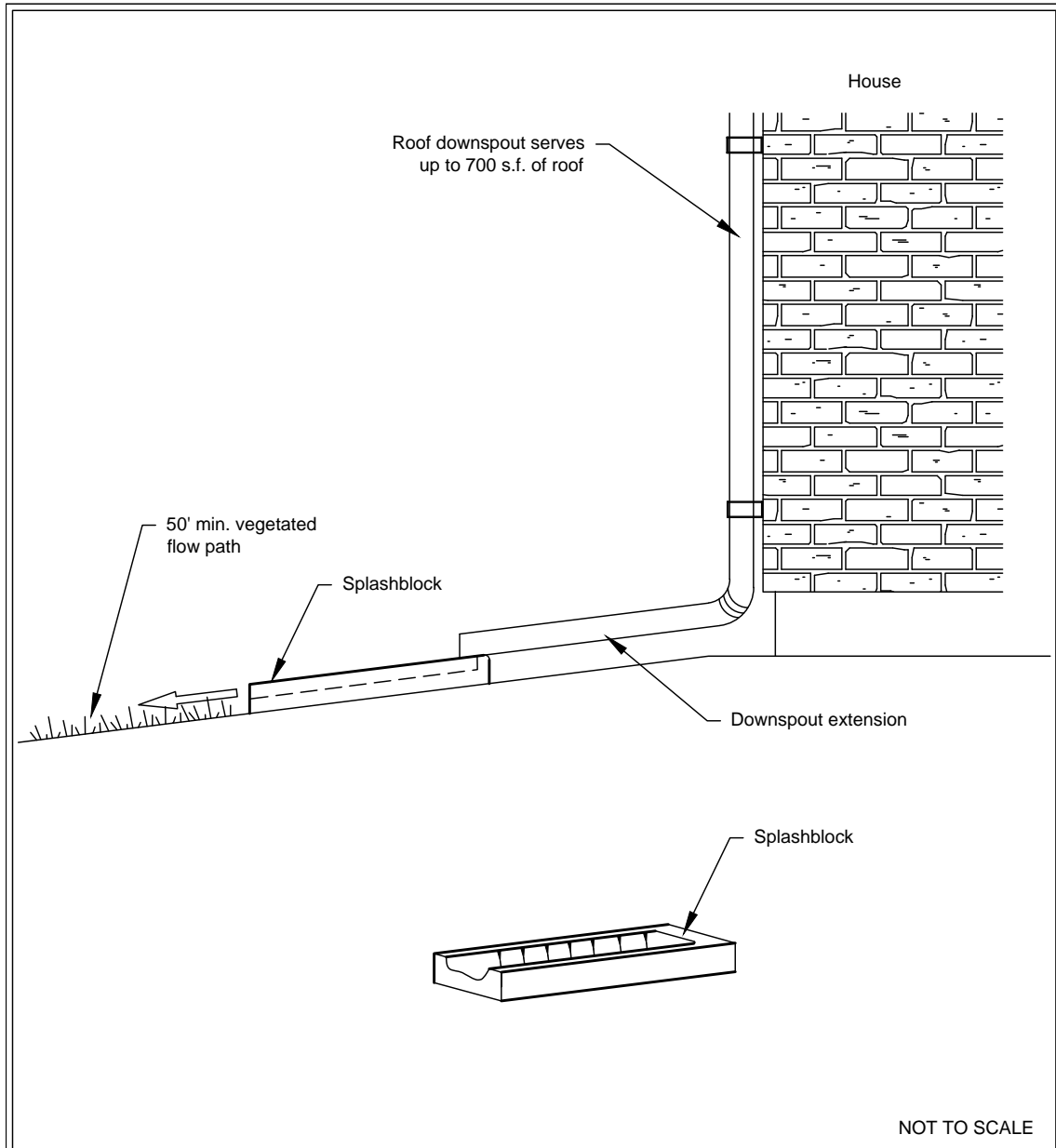

Figure III-3.1.8  
Perforated Stub-Out Connection

Revised December 2015

Please see <http://www.ecy.wa.gov/copyright.html> for copyright notice including permissions, limitation of liability, and disclaimer.

**Figure III-3.1.7 Typical Downspout Splashblock Dispersion**



**Figure III-3.1.7**  
**Typical Downspout Splashblock Dispersion**

Revised December 2015

Please see <http://www.ecy.wa.gov/copyright.html> for copyright notice including permissions, limitation of liability, and disclaimer.

(Per Volume V, Chapter 4.6 of 2014 Stormwater Management Manual for Western Washington)

### V-4.6 Maintenance Standards for Drainage Facilities

The facility-specific maintenance standards contained in this section are intended to be conditions for determining if maintenance actions are required as identified through inspection. They are not intended to be measures of the facility's required condition at all times between inspections. In other words, exceedence of these conditions at any time between inspections and/or maintenance does not automatically constitute a violation of these standards. However, based upon inspection observations, the inspection and maintenance schedules shall be adjusted to minimize the length of time that a facility is in a condition that requires a maintenance action.

**Table V-4.5.2(7) Maintenance Standards - Energy Dissipaters**

Maintenance Components	Defect	Conditions When Maintenance is Needed	Results Expected When Maintenance is Performed
External:			
Rock Pad	Missing or Moved Rock	Only one layer of rock exists above native soil in area five square feet or larger, or any exposure of native soil.	Rock pad replaced to design standards.
	Erosion	Soil erosion in or adjacent to rock pad.	Rock pad replaced to design standards.

**Table V-4.5.2(5) Maintenance Standards - Catch Basins**

Maintenance Component	Defect	Conditions When Maintenance is Needed	Results Expected When Maintenance is performed
General	Trash & Debris	<p>Trash or debris which is located immediately in front of the catch basin opening or is blocking inletting capacity of the basin by more than 10%.</p> <p>Trash or debris (in the basin) that exceeds 60 percent of the sump depth as measured from the bottom of basin to invert of the lowest pipe into or out of the basin, but in no case less than a minimum of six inches clearance from the debris surface to the invert of the lowest pipe.</p> <p>Trash or debris in any inlet or outlet pipe blocking more than 1/3 of its height.</p> <p>Dead animals or vegetation that could generate odors that could cause complaints or dangerous gases (e.g., methane).</p>	<p>No Trash or debris located immediately in front of catch basin or on grate opening.</p> <p>No trash or debris in the catch basin.</p> <p>Inlet and outlet pipes free of trash or debris.</p> <p>No dead animals or vegetation present within the catch basin.</p>
	Sediment	Sediment (in the basin) that exceeds 60 percent of the sump depth as measured from the bottom of basin to invert of the lowest pipe into or out of the basin, but in no case less than a minimum of 6 inches clearance from the sediment surface to the invert of the lowest pipe.	No sediment in the catch basin
	Structure Damage to Frame and/or Top Slab	Top slab has holes larger than 2 square inches or cracks wider than 1/4 inch. (Intent is to make sure no material is running into basin).	Top slab is free of holes and cracks. Frame is sit-

**Table V-4.5.2(5) Maintenance Standards - Catch Basins (continued)**

Maintenance Component	Defect	Conditions When Maintenance is Needed	Results Expected When Maintenance is performed
		Frame not sitting flush on top slab, i.e., separation of more than 3/4 inch of the frame from the top slab. Frame not securely attached	ting flush on the riser rings or top slab and firmly attached.
	Fractures or Cracks in Basin Walls/ Bottom	Maintenance person judges that structure is unsound. Grout fillet has separated or cracked wider than 1/2 inch and longer than 1 foot at the joint of any inlet/outlet pipe or any evidence of soil particles entering catch basin through cracks.	Basin replaced or repaired to design standards. Pipe is regouted and secure at basin wall.
	Settlement/ Misalignment	If failure of basin has created a safety, function, or design problem.	Basin replaced or repaired to design standards.
	Vegetation	Vegetation growing across and blocking more than 10% of the basin opening. Vegetation growing in inlet/outlet pipe joints that is more than six inches tall and less than six inches apart.	No vegetation blocking opening to basin. No vegetation or root growth present.
	Contamination and Pollution	See "Detention Ponds" (No. 1).	No pollution present.
Catch Basin Cover	Cover Not in Place	Cover is missing or only partially in place. Any open catch basin requires maintenance.	Catch basin cover is closed
	Locking Mechanism Not	Mechanism cannot be opened by one maintenance person with proper tools. Bolts into	Mechanism opens with

**Table V-4.5.2(5) Maintenance Standards - Catch Basins (continued)**

Maintenance Component	Defect	Conditions When Maintenance is Needed	Results Expected When Maintenance is performed
	Working	frame have less than 1/2 inch of thread.	proper tools.
	Cover Difficult to Remove	One maintenance person cannot remove lid after applying normal lifting pressure. (Intent is keep cover from sealing off access to maintenance.)	Cover can be removed by one maintenance person.
Ladder	Ladder Rungs Unsafe	Ladder is unsafe due to missing rungs, not securely attached to basin wall, misalignment, rust, cracks, or sharp edges.	Ladder meets design standards and allows maintenance person safe access.
Metal Grates (If Applicable)	Grate opening Unsafe	Grate with opening wider than 7/8 inch.	Grate opening meets design standards.
	Trash and Debris	Trash and debris that is blocking more than 20% of grate surface inletting capacity.	Grate free of trash and debris.
	Damaged or Missing.	Grate missing or broken member(s) of the grate.	Grate is in place and meets design standards.



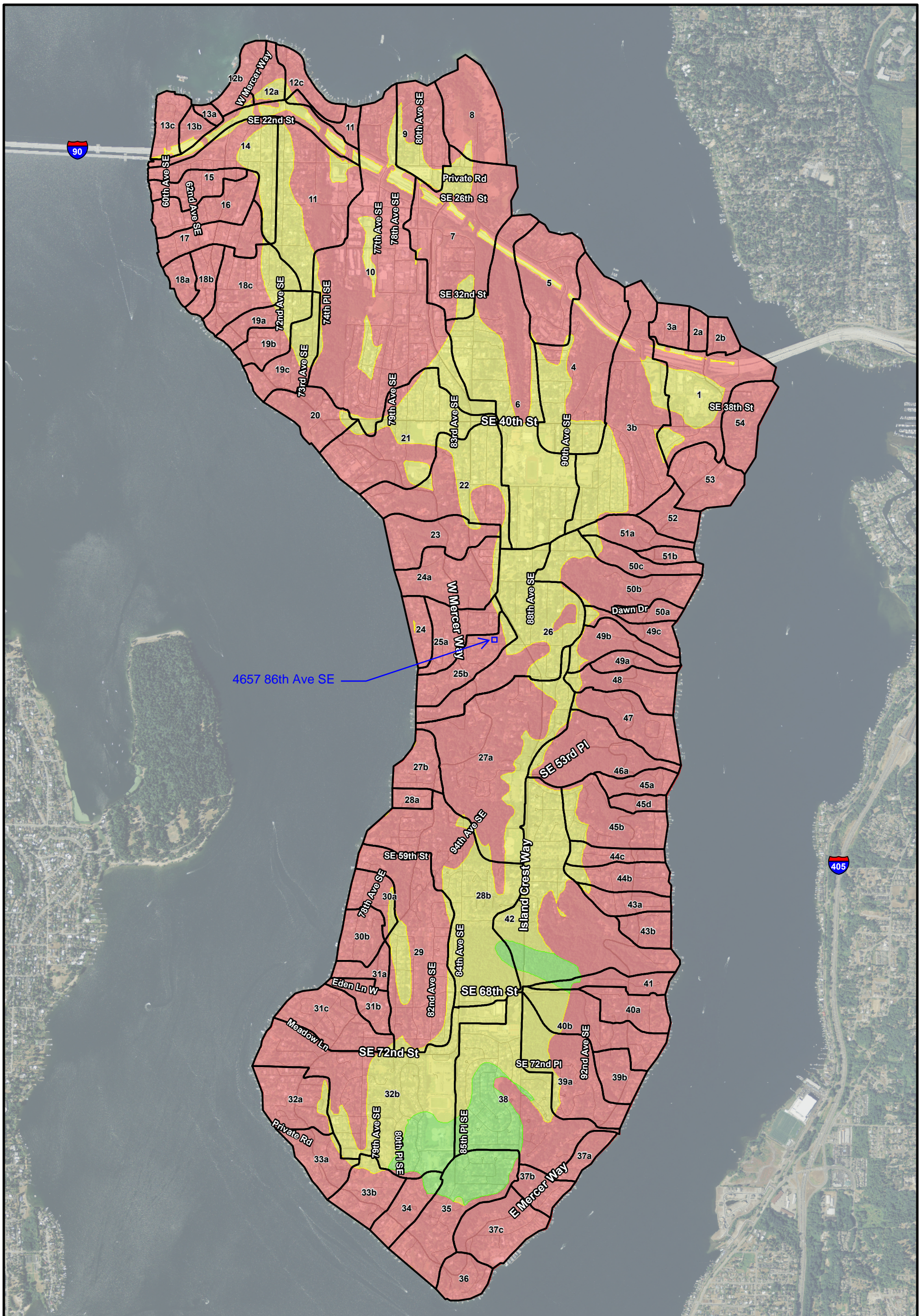

**Legend**

- Infiltrating LID facilities may be feasible, and soil has high infiltration potential
- Infiltrating LID facilities may be feasible, and soil has moderate infiltration potential
- Infiltrating LID facilities are not permitted
- Storm drainage basin

\* Map is intended to be used for planning purposes only. Site-specific analysis is required prior to design and construction of LID facilities.

**Figure 3. Low impact development infiltration feasibility on Mercer Island.**

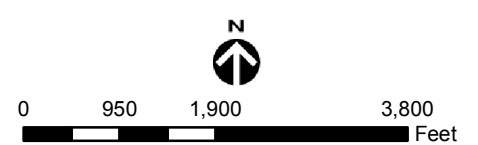





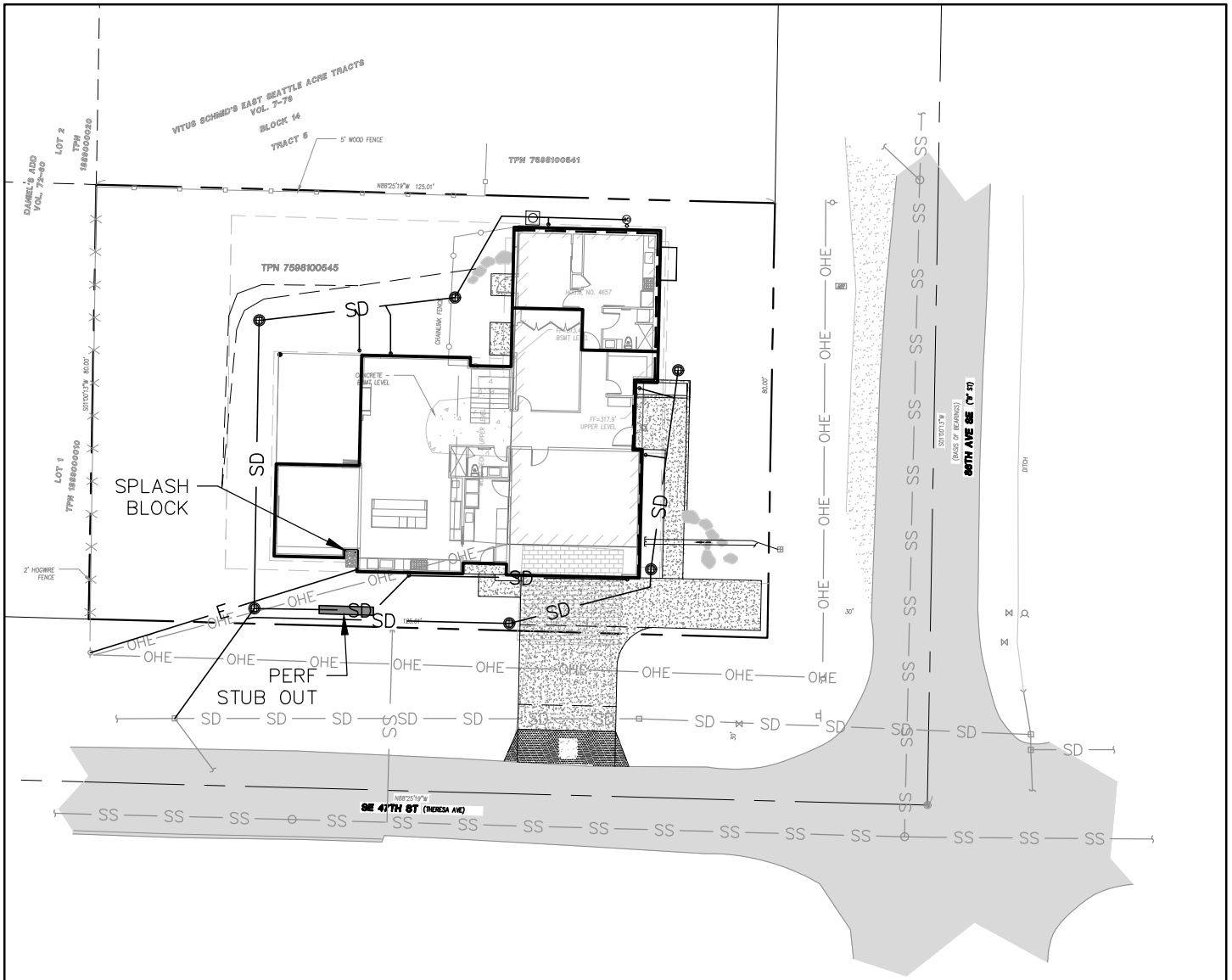

Aerial photography: USDA (2009)  
 K:\Projects\10-04816-000\Project\lid\_feasibility-report-11x17.mxd





# STORM DRAIN LEGEND

-  YARD DRAIN WITH GRATE SET AT ELEVATION TO ACCEPT SURFACE FLOW.
-  SD  6" STORM DRAIN LINE AT 0.8% MINIMUM SLOPE
-  SD  BMP T5.10A: 10' PERFORATED STUB OUT, SHEET C4.
-  CO CLEANOUT TO GRADE
-  SD BMP T5.10B: DOWNSPOUT SPLASH BLOCK

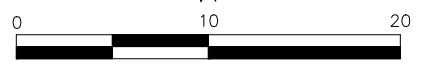
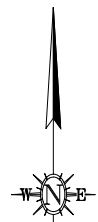

1 INCH = 30 FEET



1050 Southwood Drive  
 San Luis Obispo, CA 93401  
 P 805.544.7407 F 805.544.3863

THESE DRAWINGS ARE INSTRUMENTS OF SERVICE AND ARE THE PROPERTY OF CANNON. ALL DESIGNS AND INFORMATION ON THESE DRAWINGS ARE FOR USE OF THE SPECIFIED PROJECT AND SHALL NOT BE USED OTHERWISE OR REPRODUCED WITHOUT THE EXPRESSED WRITTEN PERMISSION OF CANNON.

4657 86TH AVE. SE – LI RESIDENCE		
DRAINAGE PLAN		
MERCER ISLAND, WA		
DRAWN BY	DATE	CA JOB NO.
KCR	10/13/2022	
CHECKED BY	SCALE	SHEET
		1 OF 1

**GENERAL SITE NOTES**

- EXISTING FEATURES, TOPOGRAPHIC AND BOUNDARY INFORMATION SHOWN ON THESE PLANS ARE FROM TOPOGRAPHIC SURVEY PROVIDED BY APEX, DATED 12/17/2021
- ALL WORK SHALL BE PERFORMED IN CONFORMANCE WITH THE FOLLOWING:
  - STANDARDS OF THE UNITED STATES DEPARTMENT OF LABOR, OCCUPATIONAL SAFETY AND HEALTH ADMINISTRATION, OFFICE OF STANDARDS AND RULES OF THE STATE DIVISION OF OCCUPATIONAL SAFETY AND HEALTH,
  - THE REQUIREMENTS OF ALL PERMITS ISSUED FOR WORK BY THE CITY OF MERCER ISLAND, WHERE CONFLICTS EXIST BETWEEN ANY OF THE ABOVE LISTED SPECIFICATIONS, THE MOST STRINGENT LISTED SPECIFICATION SHALL APPLY.
- IT IS THE RESPONSIBILITY OF THE CONTRACTOR TO SECURE ALL PERMITS NECESSARY TO PERFORM WORK, INCLUDING BUT NOT LIMITED TO WORK WITHIN THE PUBLIC RIGHT-OF-WAY, GRADING, TREE REMOVAL, AND UTILITY MODIFICATIONS.
- CONTRACTOR SHALL SUPPLY ALL EQUIPMENT, LABOR, AND MATERIALS NECESSARY TO PERFORM THE WORK SHOWN ON THE APPROVED PLANS.
- IT SHALL BE THE RESPONSIBILITY OF THE VARIOUS CONTRACTORS TO COORDINATE THEIR WORK SO AS TO ELIMINATE CONFLICTS AND WORK TOWARD THE GENERAL GOOD AND COMPLETION OF THE ENTIRE PROJECT.
- ALL WORKMANSHIP AND MATERIALS FURNISHED BY THE CONTRACTOR SHALL BE OF GOOD QUALITY AND NEW, NEITHER FINAL ACCEPTANCE NOR FINAL PAYMENT BY THE OWNER SHALL RELIEVE THE CONTRACTOR OF RESPONSIBILITY FOR FAULTY MATERIALS OR WORKMANSHIP.
- IN THE EVENT OF ANY CONFLICT OF INFORMATION SHOWN ON THE APPROVED PLANS OR ANY CONFLICT BETWEEN THE APPROVED PLANS AND THE INTENT OF A CONSISTENT AND FUNCTIONAL PRODUCT, THE CONTRACTOR SHALL SO NOTIFY THE OWNER IN WRITING, UPON WHICH NOTICE THE OWNER SHALL RESOLVE THE CONFLICTS BY THE ISSUANCE OF A WRITTEN ORDER, REVISED PLANS, OR BOTH. THE CONTRACTOR SHALL BEAR FULL COST AND RESPONSIBILITY FOR WORK AFFECTED BY SUCH CONFLICTS AND PERFORMED BY CONTRACTOR PRIOR TO SUCH NOTICE TO THE OWNER AND ISSUANCE OF SUCH ORDER AND/OR REVISED PLANS.
- CONTRACTOR SHALL EXERCISE ALL NECESSARY CAUTION TO AVOID DAMAGE TO ANY EXISTING TREES, OR SURFACE IMPROVEMENTS, OR TO ANY EXISTING DRAINAGE STRUCTURE, WATER STRUCTURE, SEWER CLEANOUTS, MANHOLES, OR JUNCTION BOXES FOR UNDERGROUND ELECTRIC, GAS, TELEPHONE, CABLE TV, STORM, SANITARY, WATER OR OTHER UTILITIES WHICH ARE TO REMAIN IN PLACE AND SHALL BEAR FULL RESPONSIBILITY FOR ANY DAMAGE THERETO.
- ALL KNOWN EXISTING UTILITY LINES ARE SHOWN FOR INFORMATION ONLY, CONTRACTOR SHALL EXERCISE ALL NECESSARY CAUTION TO ANY EXISTING UTILITY LINES OR FACILITIES TO REMAIN IN PLACE, WHETHER OR NOT SUCH FACILITIES APPEAR ON THE APPROVED PLANS, AND SHALL BEAR FULL RESPONSIBILITY FOR ANY DAMAGE THERETO.
- CONTRACTOR SHALL CONTACT THE "CALL BEFORE YOU DIG" UNDERGROUND UTILITY LOCATING SERVICE (811) AND THE AFFECTED UTILITY COMPANY PRIOR TO STARTING WORK TO REQUEST AND OBTAIN MARKING OF EXISTING UNDERGROUND FACILITIES.
- CONTRACTORS SHALL HIRE A LICENSED LAND SURVEYOR TO PROVIDE CONSTRUCTION STAKING IN ORDER TO ENSURE THE PROJECT IS CONSTRUCTED TO THE LINES AND GRADES INDICATED ON THE APPROVED PLANS.
- INSPECTION OF WORK: CONTRACTOR SHALL BE RESPONSIBLE FOR THE COORDINATION OF REQUIRE INSPECTIONS WITH THE APPROPRIATE AGENCIES AND UTILITY COMPANIES AND CITY OF MEDINA STANDARDS.
- ENGINEER OF RECORD SHALL BEAR NO RESPONSIBILITY FOR METHODS AND PROCEDURES OF WORK ESTABLISHED BY CONTRACTOR, JOBSITE CONDITIONS, JOBSITE SAFETY, OR CONFORMANCE WITH SAFETY PROCEDURES AND REQUIREMENTS.
- IN CONFORMANCE WITH GENERALLY ACCEPTED CONSTRUCTION PRACTICES, THE CONTRACTOR SHALL ASSUME SOLE AND COMPLETE RESPONSIBILITY FOR THE JOBSITE CONDITIONS DURING THE COURSE OF CONSTRUCTION OF THE PROJECT, INCLUDING SAFETY OF ALL PERSONS AND PROPERTY, THIS REQUIREMENT SHALL APPLY CONTINUOUSLY AND SHALL NOT BE LIMITED TO NORMAL WORKING HOURS. THE CONTRACTOR SHALL INDEMNIFY AND HOLD HARMLESS BOTH THE OWNER AND ENGINEER FROM ANY AND ALL LIABILITY REAL OR ALLEGED IN CONNECTION WITH THE PERFORMANCE OF THE WORK ON THIS PROJECT, EXCEPTING LIABILITY ARISING FROM THE SOLE NEGLIGENCE OF THE OWNER OR ENGINEER OF RECORD.
- ALL UNSUITABLE MATERIALS SHALL BE REMOVED FROM THE PROJECT AND BE PLACED AT A SUITABLE DISPOSAL SITE.

# LI RESIDENCE

## 4657 86TH AVE. SE

### MERCER ISLAND, WASHINGTON

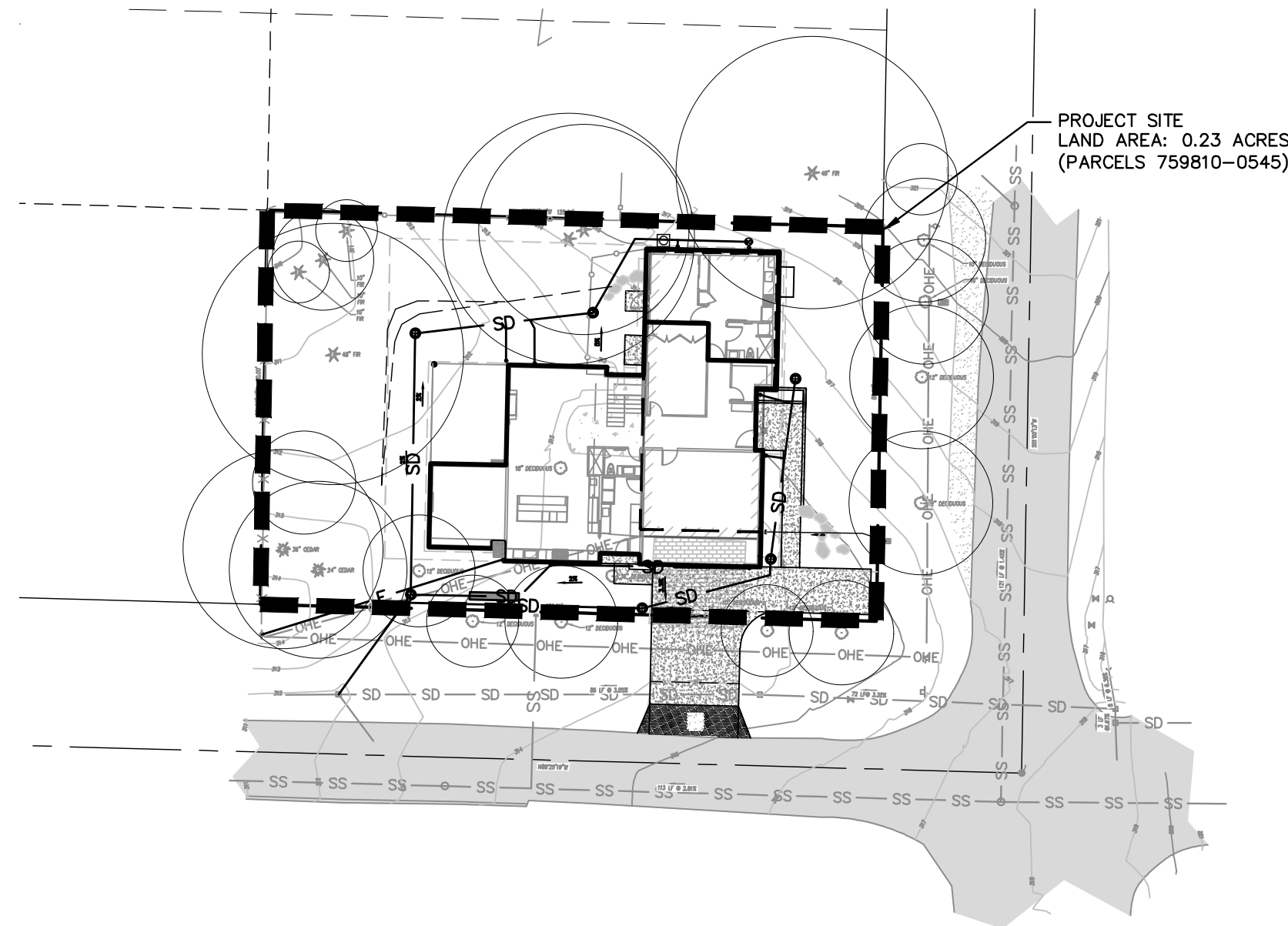

**PROJECT SITE**  
1" = 30'

**PROJECT INFORMATION:**

SITE ADDRESS: 4657 86TH AVE. SE,  
MERCER ISLAND, WA 98040

PARCEL NUMBER: 7598100545

LEGAL DESCRIPTION: (PER STATUTORY WARRANTY DEED, KING CO, REC. NO. 20211005001771)

THE SOUTH 80 FEET OF THE EAST 125 FEET OF TRACT 5 IN BLOCK 14 OF THE VITUS SCHMID'S EAST SEATTLE, ACRE TRACTS, AS PER PLAT RECORDED IN VOLUME 7 OF PLATS, PAGE 76, RECORDS OF KING COUNTY AUDITOR.

SITUATE IN THE CITY OF MERCER ISLAND, COUNTY OF KING, STATE OF WASHINGTON.

**UTILITIES:**

**WATER:**  
CITY OF MERCER ISLAND  
611 SE 36TH STREET,  
MERCER ISLAND, WA 98040  
(206) 275-7602

**SEWER:**  
CITY OF MERCER ISLAND  
611 SE 36TH STREET,  
MERCER ISLAND, WA 98040  
(206) 275-7602

**FIRE:**  
MERCER ISLAND FIRE DEPARTMENT

**ELECTRIC/GAS:**  
PSE

**OWNER:**

PAUL LI  
(703)965-9722

**DEVELOPER:**

CAMERON WEAVER  
WW SUSTAINABLE, LLC  
23815 140TH AVE. SE  
KENT, WA 98042

**CIVIL ENGINEER:**

CANNON  
ATTN: KATIE ROLLINS  
PE: ED COLLINS  
PHONE: (425) 677-2325  
1700 NW GILMAN BLVD, SUITE 100  
ISSAQUAH, WA 98027

**SURVEYOR:**

APEX ENGINEERING LLC  
2601 SOUTH 35TH STREET, SUITE 200  
TACOMA, WA 98409  
253 473-0599

**ARCHITECT:**

LURE DESIGN SOLUTIONS  
13842 NE 8TH STREET, #E102  
BELLEVUE, WA 98005  
(425) 870-0383



**VICINITY MAP**  
NTS

**ABBREVIATIONS**

ASPHALT CONCRETE	AC	EDGE OF PAVEMENT	EP
CENTERLINE	CL / C	MANHOLE RIM ELEVATION	RM
BACK OF WALK	BOW	MATCH EXISTING	ME
EACH WAY	E.W.	ON CENTER	O.C.
EXISTING GRADE	EG	RIGHT OF WAY	ROW
EXISTING	(E)	STANDARD	STD
FINISHED SURFACE	FS	STORM DRAIN	SD
FINISHED GRADE	FG	SANITARY SEWER	SS
HIGH POINT	HP	TOP OF CURB	TC
INVERT	INV	TOP OF GRADE	TG
MINIMUM	MIN	BOTTOM OF WALL	BW
PROPERTY LINE	PL / R	TOP OF WALL	TW
PUBLIC UTILITY EASEMENT	PUE	UNLESS NOTED OTHERWISE	U.N.O.
		UNIFORM PLUMBING CODE	UPC

**LEGEND**

	EXISTING	PROPOSED
LOT BOUNDARY	---	---
PROPERTY LINE	---	---
EASEMENT/SETBACK	---	---
STREET CENTERLINE	---	---
BUILDING	[Hatched Box]	[Hatched Box]
GRADE BREAK	---	---
CONTOURS	---	---
WATER MAIN OR LATERAL	W	W
SANITARY SEWER	SS	SS
STORM DRAIN LINE	SD	SD
GAS LINE	G	G
FOUNDATION DRAIN	FD	FD
DRY UTILITY LATERAL	---	---
AC PAVING	[Hatched Box]	[Hatched Box]
CONCRETE	[Hatched Box]	[Hatched Box]
STORM DRAIN INLET	[Circle]	[Circle]
CLEANOUT TO GRADE	[Circle]	[Circle]
YARD DRAIN	[Circle]	[Circle]
JUNCTION BOX	[Circle]	[Circle]
CATCH BASIN	[Square]	[Square]
DOWNSPOUT SPLASH	[Square]	[Square]

**SHEET INDEX**

No.	SHEET TITLE
C1	TITLE SHEET
C2	DRAINAGE & BMP PLAN
C3	UTILITY CONNECTIONS PLAN
C4	GRADING AND DRAINAGE DETAILS
C5	TESC PLAN
C6	TESC NOTES AND STANDARD DETAILS
C7	TESC DETAILS
C8	TESC DETAILS



REV. NO	DATE	REVISED	DESTROY ALL PRINTS BEARING EARLIER DATE	REV. BY	CKD. BY	APRD BY

1050 Southwood Drive  
San Luis Obispo, CA 93401  
P 805.544.7407 F 805.544.3863

THESE DRAWINGS ARE INSTRUMENTS OF SERVICE AND ARE THE PROPERTY OF CANNON. ALL DESIGNS AND INFORMATION ON THESE DRAWINGS ARE FOR USE OF THE SPECIFIED PROJECT AND SHALL NOT BE USED OTHERWISE OR REPRODUCED WITHOUT THE EXPRESSED WRITTEN PERMISSION OF CANNON.

LI RESIDENCE		
TITLE SHEET		
MERCER ISLAND, WASHINGTON		
DRAWN BY SEM	DATE 10/11/2022	CA JOB NO. 220418
CHECKED BY KR	SCALE AS SHOWN	SHEET C1 OF 8

EXISTING UNDERGROUND UTILITY INFORMATION SHOWN ON THESE PLANS IS BASED UPON A COMBINATION OF SOURCES INCLUDING FIELD TOPOGRAPHIC SURVEY AND CITY SYSTEM MAPS. CONTRACTOR SHALL BE ADVISED THAT UNDERGROUND UTILITIES NOT IDENTIFIED ON THESE PLANS MAY EXIST WITHIN THE PROJECT SITE, AND SHALL EXERCISE APPROPRIATE CARE DURING EXCAVATION ACTIVITIES. CONTRACTOR SHALL POthOLE AND FIELD VERIFY EXISTING UNDERGROUND UTILITY SIZE AND LOCATIONS AT CRITICAL LOCATIONS PRIOR TO CONSTRUCTION, AND NOTIFY ENGINEER IF DISCREPANCIES EXIST.

**CONSTRUCTION NOTES**

- ① NOT USED.
- ② EXISTING RAISED FOOTING TO REMAIN. DAYLIGHT FOUNDATION DRAIN.
- ③ CONNECT DOWNSPOUT STORMDRAIN LINE.
- ④ RURAL DRIVEWAY APRON PER MODIFIED KING COUNTY STANDARD FIG 3-003 ON SHEET C4. OMIT PIPE.

**GENERAL NOTES**

- 1. ALL GRADING AND DRAINAGE SHALL CONFORM TO THE CURRENT BUILDING CODE.
- 2. TOP OF WALL "TW" ELEVATIONS DEPICT TOP OF WALL ELEVATION AS DESIGNATED BY THE LANDSCAPE ARCHITECT.
- 3. ALL DISTURBED PERVIOUS AREA SHALL BE AMENDED PER BMP 15.13 (POST-CONSTRUCTION SOIL QUALITY AND DEPTH) (SEE DETAIL B, SHEET C4)
- 4. CONSTRUCT TRENCH PLUGS IN UTILITY TRENCHES AS DIRECTED BY THE GEOTECHNICAL ENGINEER AT THE TIME OF CONSTRUCTION TO PREVENT WATER INTRUSION INTO THE BUILDING AND SLAB.
- 5. POOL DESIGN WILL INCLUDE PROVISIONS TO PREVENT FLOATATION.

**GRADING NOTES**

- 1. PRIOR TO CONSTRUCTING FLATWORK NEAR EXTERIOR DOORS, CONTRACTOR SHALL COORDINATE DOOR THRESHOLD DROP WITH ARCHITECTURAL PLANS.
- 2. ALL FLATWORK ADJACENT TO BUILDINGS SHALL BE SLOPED AT A MINIMUM OF 2% FOR 10' AWAY FROM THE BUILDING UNLESS NOTED OTHERWISE.
- 3. FINISHED GRADE (PERVIOUS AREA) DIRECTLY ADJACENT TO BUILDINGS SHALL BE SLOPED AT 5% MINIMUM FOR 10' AWAY FROM THE BUILDING, OR TO A DESIGNATED SWALE SLOPED AT 2% MINIMUM.
- 4. FINISHED GRADE (DIRT OR LANDSCAPE AREA) DIRECTLY OUTSIDE OF THE BUILDING SHALL BE 8" MINIMUM AND 12" MAXIMUM BELOW FINISHED FLOOR UNLESS NOTED WITH A SPECIALLY DESIGNED FOOTING. FOOTING EMBEDMENT SHOULD MEET MINIMUM REQUIREMENTS PER STRUCTURAL ENGINEER.
- 5. NO SLOPES SHALL EXCEED 2:1 HORIZONTAL TO VERTICAL.
- 6. DRIVEWAYS SHALL NOT EXCEED 20% MAX SLOPE THROUGH EXPECTED DRIVE PATH.
- 7. CONTRACTOR TO INSTALL STAIRS, STAIR LANDINGS AND HANDRAILS AS REQUIRED BY THE WASHINGTON BUILDING CODE.
- 8. PRIOR TO CONSTRUCTION, PROJECT GEOTECHNICAL ENGINEER SHALL REVIEW AND APPROVE THESE PLANS FOR CONFORMANCE WITH THEIR RECOMMENDATIONS, INCLUDING EARTHWORK AND GRADING, FOUNDATION AND WALL DRAINS, INFILTRATING STORMWATER BMPS, BUILDING PAD PREPARATION.
- 9. PROVIDE LANDINGS OUTSIDE OF ALL EXTERIOR DOORS PER WASHINGTON BUILDING CODE.

**STORM DRAIN LEGEND**

- ⊕ YARD DRAIN WITH GRATE SET AT ELEVATION TO ACCEPT SURFACE FLOW.
- SD 6" STORM DRAIN LINE AT 0.8% MINIMUM SLOPE
- ⊞ BMP 15.10A: 10' PERFORATED STUB OUT, SHEET C4.
- ⊞ CLEANOUT TO GRADE
- ⊞ BMP 15.10B: DOWNSPOUT SPLASH BLOCK

**STORM DRAINAGE NOTES**

- 1. STORM PIPE SHALL BE PVC CONFORMING TO ASTM D-3034 SDR 35 (4" - 15") OR ASTM F-679 (18"-27"). BEDDING AND BACKFILL SHALL BE AS SHOWN IN THE STANDARD DETAILS.
- 2. INSTALL FOOTING DRAINS AROUND ALL BUILDING PERIMETER FOOTINGS. THE FOOTING DRAINAGE SYSTEM AND THE ROOF DOWNSPOUT SYSTEM SHALL NOT BE INTERCONNECTED AND SHALL SEPARATELY CONVEY COLLECTED FLOWS TO THE CONVEYANCE SYSTEM OR TO ON-SITE STORMWATER FACILITIES.
- 3. CONNECT ALL ROOF DRAIN DOWNSPOUTS TO BELOW GROUND STORM DRAIN SYSTEM, UNLESS SPLASH BLOCK SHOWN.
- 4. YARD DRAIN CATCH BASINS SHALL BE NYLOPLAST DRAIN BASIN WITH 8" CIRCLE GRATE (UNLESS OTHERWISE NOTED) OR APPROVED EQUAL (DRAIN BASIN SHALL BE 12" MIN OR LARGER TO ACCOMMODATE CONNECTED PIPES). SEE DETAIL C ON SHEET C4. CATCH BASINS WITHIN DRIVEWAY OR OTHER VEHICULAR AREAS SHALL HAVE TRAFFIC RATED GRATE AND FRAME. SEE NOTE 8.
- 5. PROVIDE BACK OF WALL DRAINS BEHIND ALL RETAINING WALLS.
- 6. PIPES ROUTED BELOW RETAINING WALLS SHALL BE SUFFICIENTLY PROTECTED FROM WALL LOADING. FOR LANDSCAPE WALLS, PROVIDE 6" SLURRY ENCASEMENT OF PIPE AT MINIMUM WITHIN THE ZONE OF INFLUENCE OF WALL.
- 7. YARD DRAIN TYPE AND MANUFACTURER FOR YARD DRAINS THAT ARE NOT ON THE MAIN STORM DRAIN CONVEYANCE LINE SHALL BE COORDINATED BY LANDSCAPE ARCHITECT.

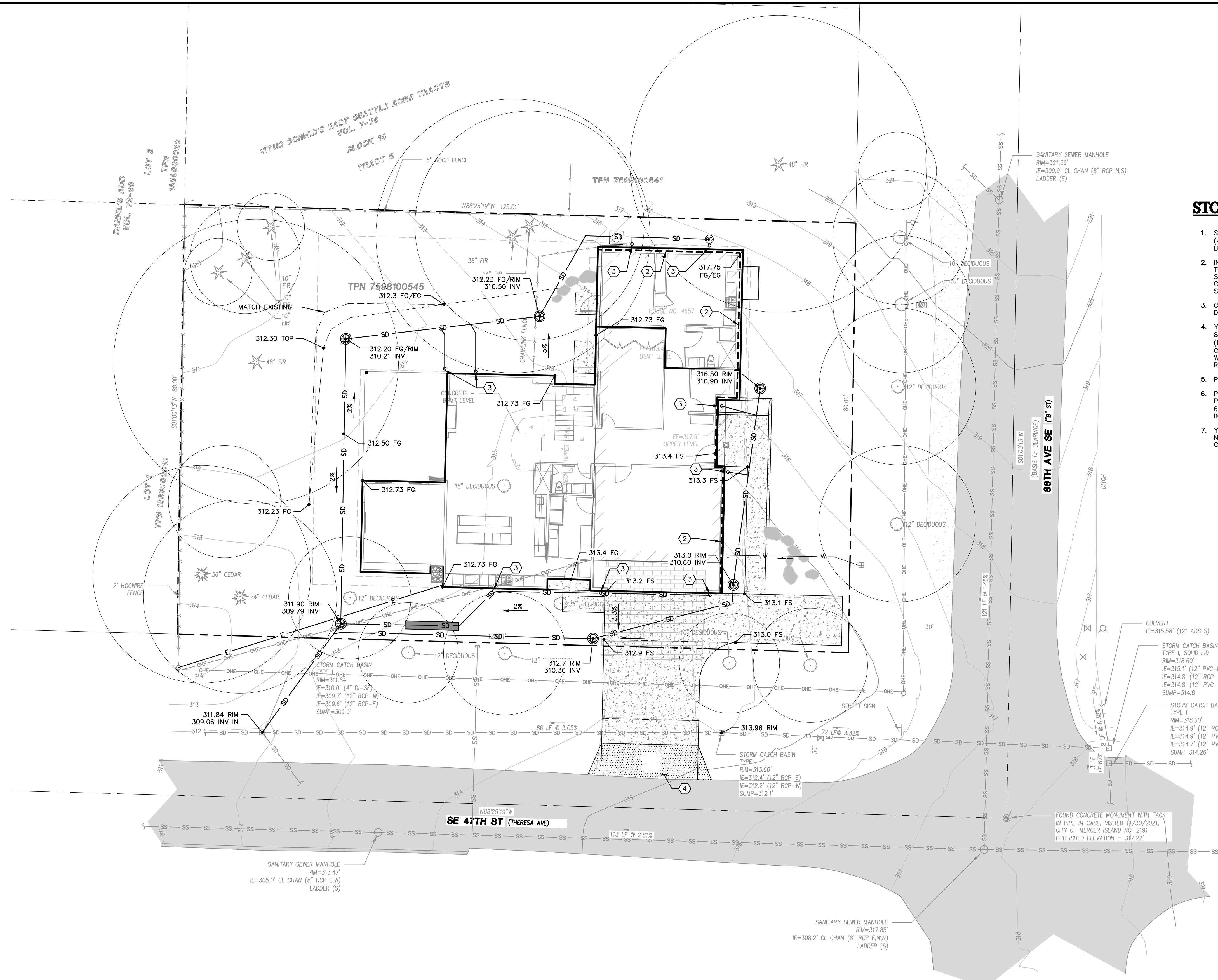

REV. NO	DATE	REVISED	DESTROY ALL PRINTS BEARING EARLIER DATE	REV. BY	CKD. BY	APRD BY

**Cannon**  
 1050 Southwood Drive  
 San Luis Obispo, CA 93401  
 P 805.544.7407 F 805.544.3863

THESE DRAWINGS ARE INSTRUMENTS OF SERVICE AND ARE THE PROPERTY OF CANNON. ALL DESIGNS AND INFORMATION ON THESE DRAWINGS ARE FOR USE OF THE SPECIFIED PROJECT AND SHALL NOT BE USED OTHERWISE OR REPRODUCED WITHOUT THE EXPRESSED WRITTEN PERMISSION OF CANNON.

**LI RESIDENCE**

**DRAINAGE & BMP PLAN**

**MERCER ISLAND, WASHINGTON**

DRAWN BY SEM	DATE 10/11/2022	CA JOB NO. 220418
CHECKED BY KR	SCALE AS SHOWN	SHEET C2 OF 8

F:\proj\2022\220418\4 Production and Drafting\Const Dwg\Civil\Ce220418SP0001.dwg 10-13-22 05:45:34 PM katie

**CONSTRUCTION NOTES**

- 20 CONNECT PROPOSED SEWER TO EXISTING SEWER LATERAL.
- 21 EXISTING 5/8" WATER METER. UPSIZING PER CITY REQUIREMENTS.
- 22 PROPOSED UNDERGROUND ELECTRICAL SERVICE.

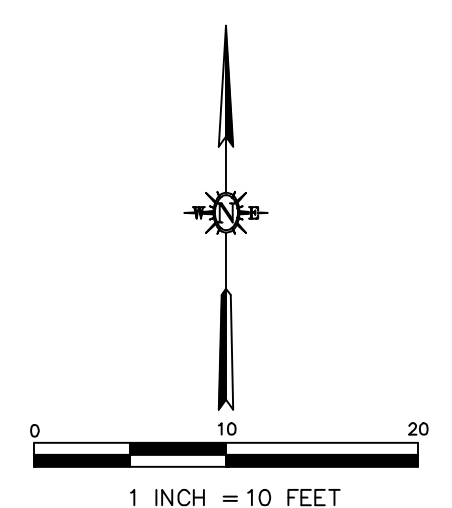
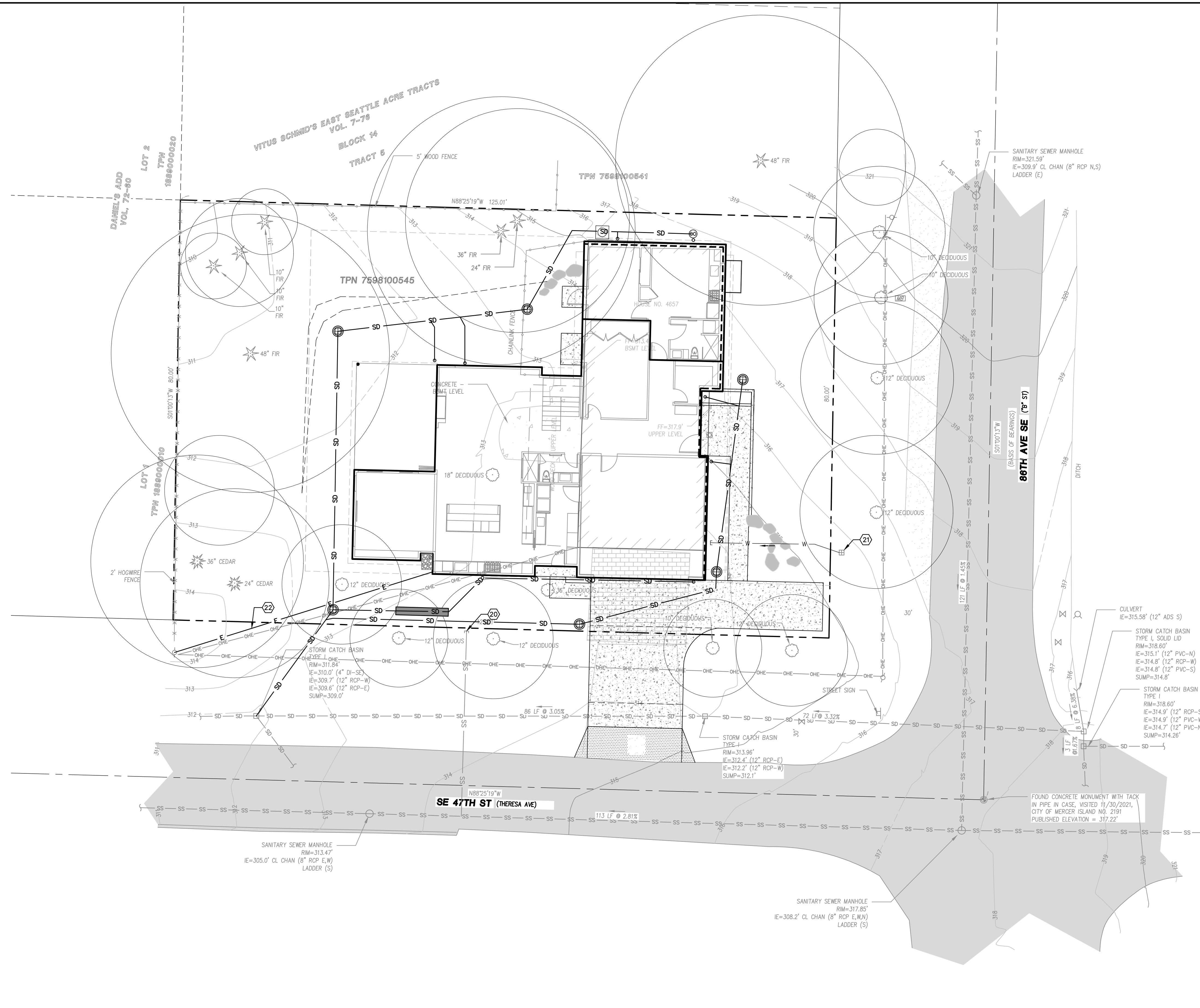

REV. NO	DATE	REVISED	DESTROY ALL PRINTS BEARING EARLIER DATE	REV. BY	CKD. BY	APRD BY

1050 Southwood Drive  
San Luis Obispo, CA 93401  
P 805.544.7407 F 805.544.3863

THESE DRAWINGS ARE INSTRUMENTS OF SERVICE AND ARE THE PROPERTY OF CANNON. ALL DESIGNS AND INFORMATION ON THESE DRAWINGS ARE FOR USE OF THE SPECIFIED PROJECT AND SHALL NOT BE USED OTHERWISE OR REPRODUCED WITHOUT THE EXPRESSED WRITTEN PERMISSION OF CANNON.

<b>LI RESIDENCE</b>		
<b>UTILITY CONNECTIONS PLAN</b>		
<b>MERCER ISLAND, WASHINGTON</b>		
DRAWN BY <b>SEM</b>	DATE <b>10/11/2022</b>	CA JOB NO. <b>220418</b>
CHECKED BY <b>KR</b>	SCALE <b>AS SHOWN</b>	SHEET <b>C3 OF 8</b>

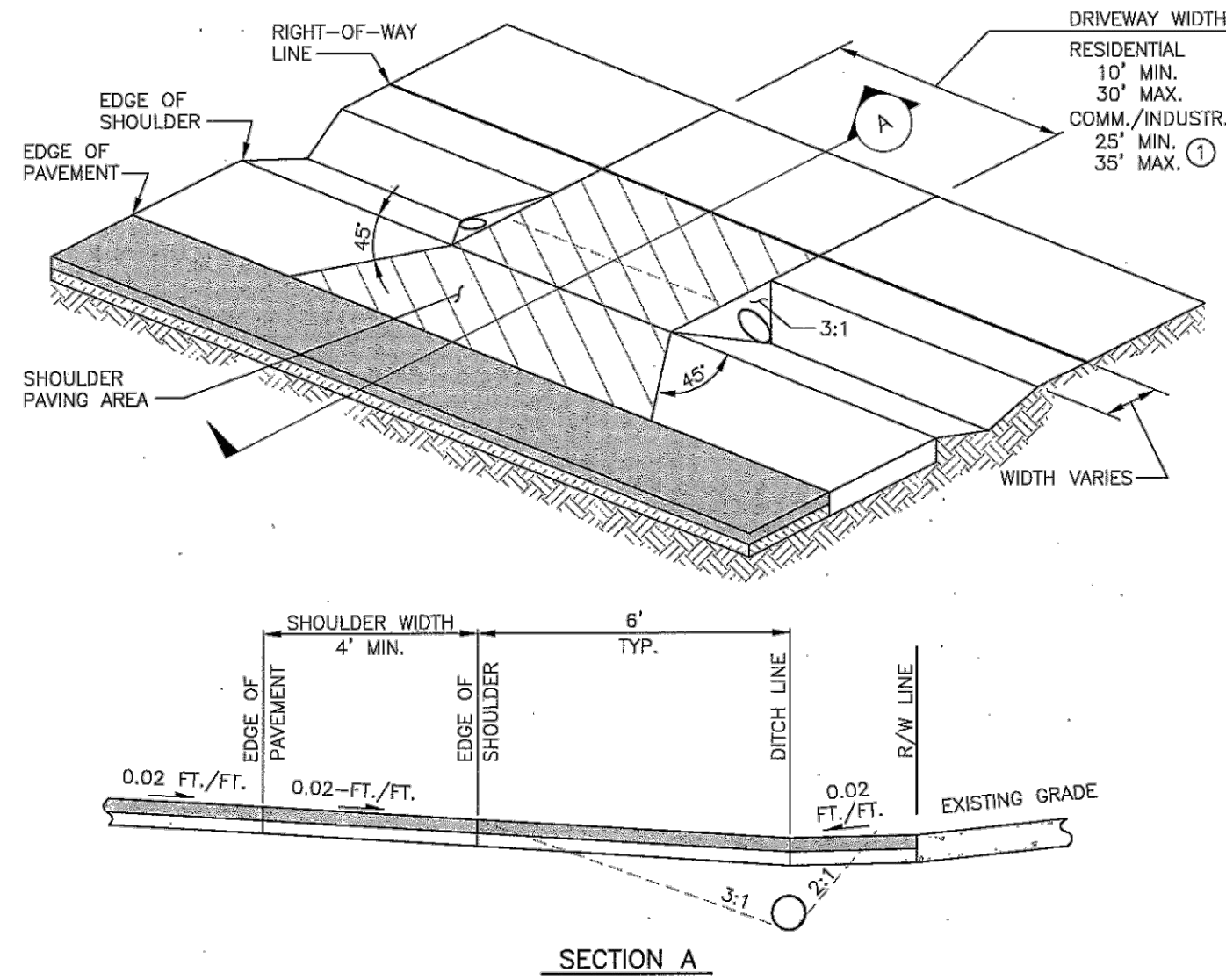

- NOTES:**
- WITHIN THE RIGHT-OF-WAY DRIVEWAYS SHALL BE PAVED FROM THE RIGHT-OF-WAY LINE TO THE EDGE OF PAVEMENT WITH HOT MIX ASPHALT. NO CONCRETE IS ALLOWED WITHIN THE RIGHT-OF-WAY UNLESS AS SPECIFIED IN SEC.4.02.
  - COMMERCIAL/INDUSTRIAL DRIVEWAYS WIDER THAN 35 FT. MAY BE APPROVED BY THE COUNTY ROAD ENGINEER CONSIDERING BOTH TRAFFIC SAFETY AND THE ACTIVITY BEING SERVED. ALL COMMERCIAL/INDUSTRIAL DRIVEWAYS SHALL HAVE AN EXPANSION JOINT LOCATED MID-WIDTH. (SEE SEC. 3.04.)
  - PIPE SHALL BE:
    - SIZED TO CONVEY COMPUTED STORM WATER RUNOFF, AND
    - MIN. 12" DIAM., AND
    - EQUAL TO OR LARGER THAN EXISTING PIPES WITHIN 500 FT. UPSTREAM.
  - EXPOSED PIPE ENDS SHALL BE REVEALED TO MATCH THE SLOPE FACE AND PROJECT NO MORE THAN 2" BEYOND SLOPE SURFACE. PROJECTING HEADWALLS ARE NOT ACCEPTABLE.
  - ALL TYPES OF PIPE SHALL HAVE MIN. 12" COVER TO FINISH GRADE.
  - PIPE SHALL BE INSTALLED IN A STRAIGHT UNIFORM ALIGNMENT AT A MIN. 0.5% SLOPE (0.5 FT. PER 100 FT.) WITH THE DOWNSTREAM END LOWER THAN THE UPSTREAM END.
  - PIPE MAY BE OMITTED IF ROADSIDE DITCH DOES NOT EXIST AND DRIVEWAY DOES NOT BLOCK NATURAL FLOW.
  - DRIVEWAY SLOPE SHALL MATCH TO BACK EDGE OF SHOULDER, BUT SHOULDER SLOPE AND EDGE OF SHOULDER SHALL NOT BE ALTERED AS A RESULT OF DRIVEWAY CONSTRUCTION.
  - SEE SEC. 3.01 AND 4.01 FOR DRIVEWAY AND SURFACING STANDARDS.
  - PIPING OF DITCHES SHALL BE ALLOWED ONLY WHERE DRIVEWAY ACCESS IS NECESSARY.

Figure III-3.1.8 Perforated Stub-Out Connection

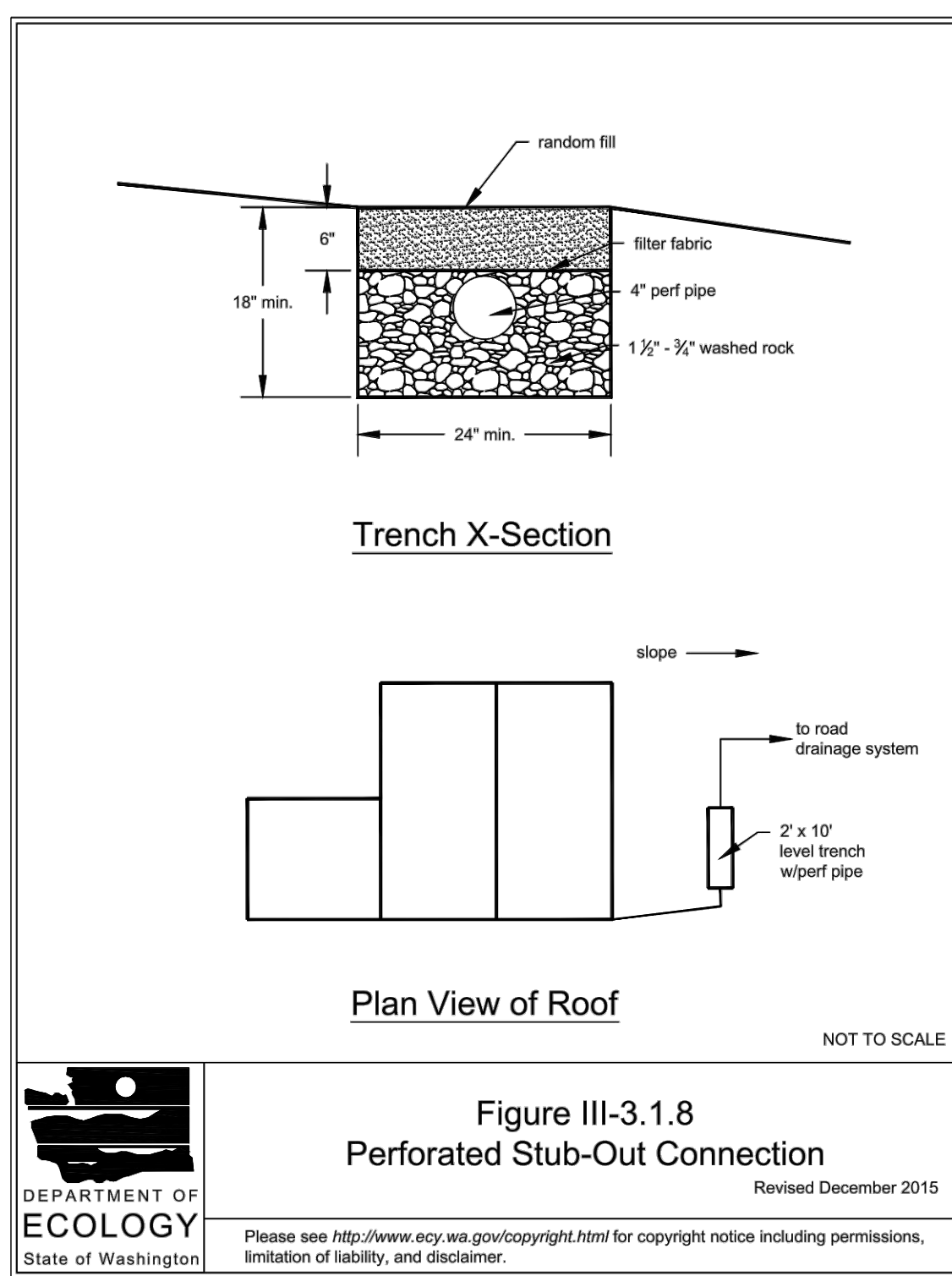

Figure III-3.1.8 Perforated Stub-Out Connection  
Revised December 2015

2014 Stormwater Management Manual for Western Washington  
Volume III - Chapter 3 - Page 466

**BMP T5.13: Post-Construction Soil Quality and Depth**

**Applications and Limitations**

Establishing a minimum soil quality and depth is not the same as preservation of naturally occurring soil and vegetation. However, establishing a minimum soil quality and depth will provide improved on-site management of stormwater flow and water quality.

Soil organic matter can be attained through numerous materials such as compost, composted woody material, biosolids, and forest product residuals. It is important that the materials used to meet the soil quality and depth BMP be appropriate and beneficial to the plant cover to be established. Likewise, it is important that imported topsoils improve soil conditions and do not have an excessive percent of clay fines.

This BMP can be considered infeasible on till soil slopes greater than 33 percent.

**Design Guidelines**

- Soil retention.** Retain, in an undisturbed state, the duff layer and native topsoil to the maximum extent practicable. In any areas requiring grading remove and stockpile the duff layer and topsoil on site in a designated, controlled area, not adjacent to public resources and critical areas, to be reapplied to other portions of the site where feasible.
- Soil quality.** All areas subject to clearing and grading that have not been covered by impervious surface, incorporated into a drainage facility or engineered as structural fill or slope shall, at project completion, demonstrate the following:
  - A topsoil layer with a minimum organic matter content of 10% dry weight in planting beds, and 5% organic matter content in turf areas, and a pH from 6.0 to 8.0 or matching the pH of the undisturbed soil. The topsoil layer shall have a minimum depth of eight inches except where tree roots limit the depth of incorporation of amendments needed to meet the criteria. Subsoils below the topsoil layer should be scarified at least 4 inches with some incorporation of the upper material to avoid stratified layers, where feasible.
  - Mulch planting beds with 2 inches of organic material

- Use compost and other materials that meet these organic content requirements:
  - The organic content for "pre-approved" amendment rates can be met only using compost meeting the compost specification for [BMP T7.30: Bioretention Cells, Swales, and Planter Boxes \(p.959\)](#), with the exception that the compost may have up to 35% biosolids or manure. The compost must also have an organic matter content of 40% to 65%, and a carbon to nitrogen ratio below 25:1. The carbon to nitrogen ratio may be as high as 35:1 for plantings composed entirely of plants native to the Puget Sound Lowlands region.
  - Calculated amendment rates may be met through use of composted material meeting (a.) above; or other organic materials amended to meet the carbon to nitrogen ratio requirements, and not exceeding the contaminant limits identified in Table 220-B, Testing Parameters, in [WAC 173-350-220](#).

The resulting soil should be conducive to the type of vegetation to be established.

- Implementation Options:** The soil quality design guidelines listed above can be met by using one of the methods listed below:
  - Leave undisturbed native vegetation and soil, and protect from compaction during construction.
  - Amend existing site topsoil or subsoil either at default "pre-approved" rates, or at custom calculated rates based on tests of the soil and amendment.
  - Stockpile existing topsoil during grading, and replace it prior to planting. Stockpiled topsoil must also be amended if needed to meet the organic matter or depth requirements, either at a default "pre-approved" rate or at a custom calculated rate.
  - Import topsoil mix of sufficient organic content and depth to meet the requirements.

More than one method may be used on different portions of the same site. Soil that already meets the depth and organic matter quality standards, and is not compacted, does not need to be amended.

SOIL QUALITY AND DEPTH

B

SHOULDER AND DITCH SECTION DRIVEWAY  
3-14

FIG. 3-003

PERFORATED STUBOUT CONNECTIONS

A

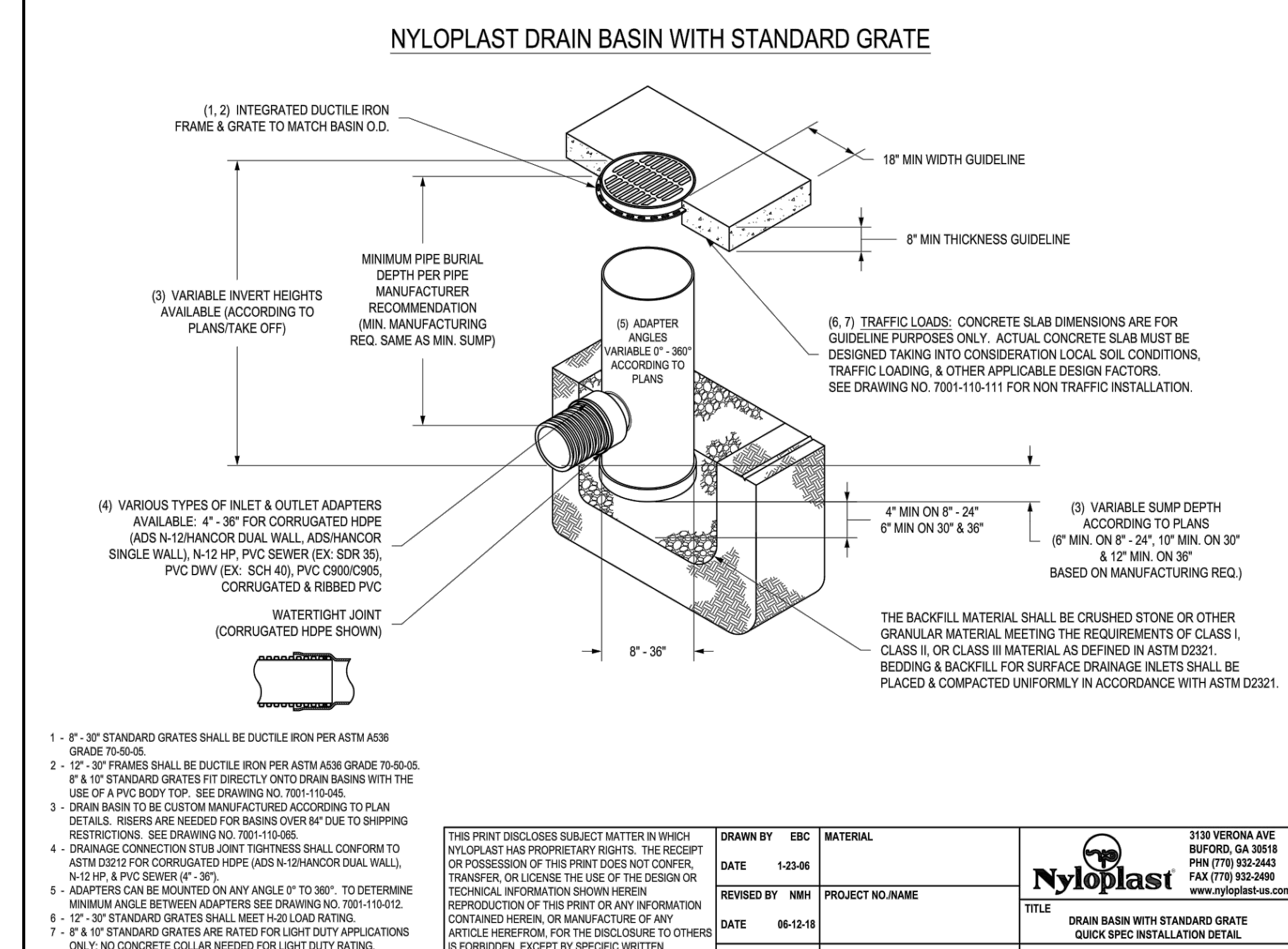
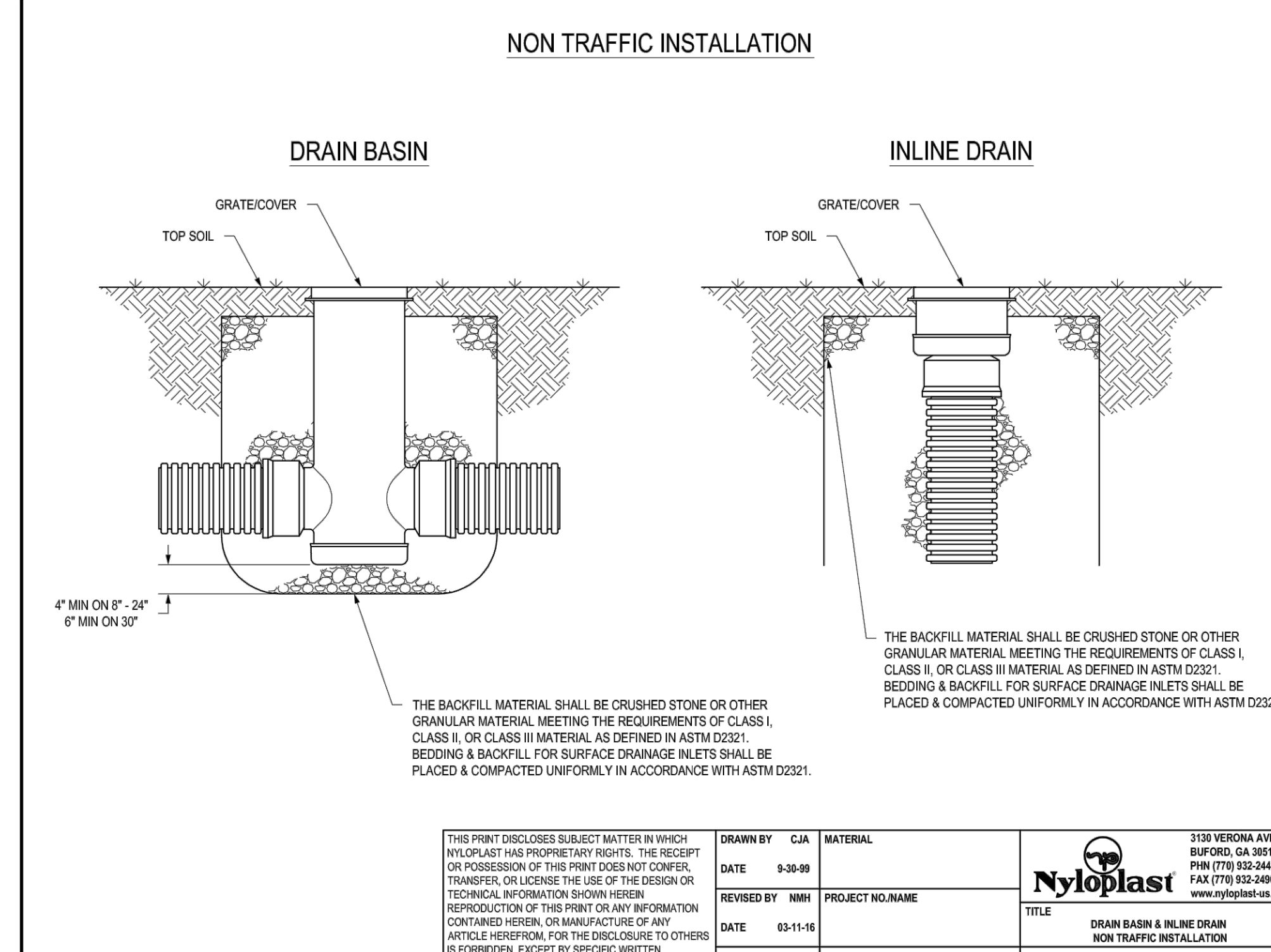
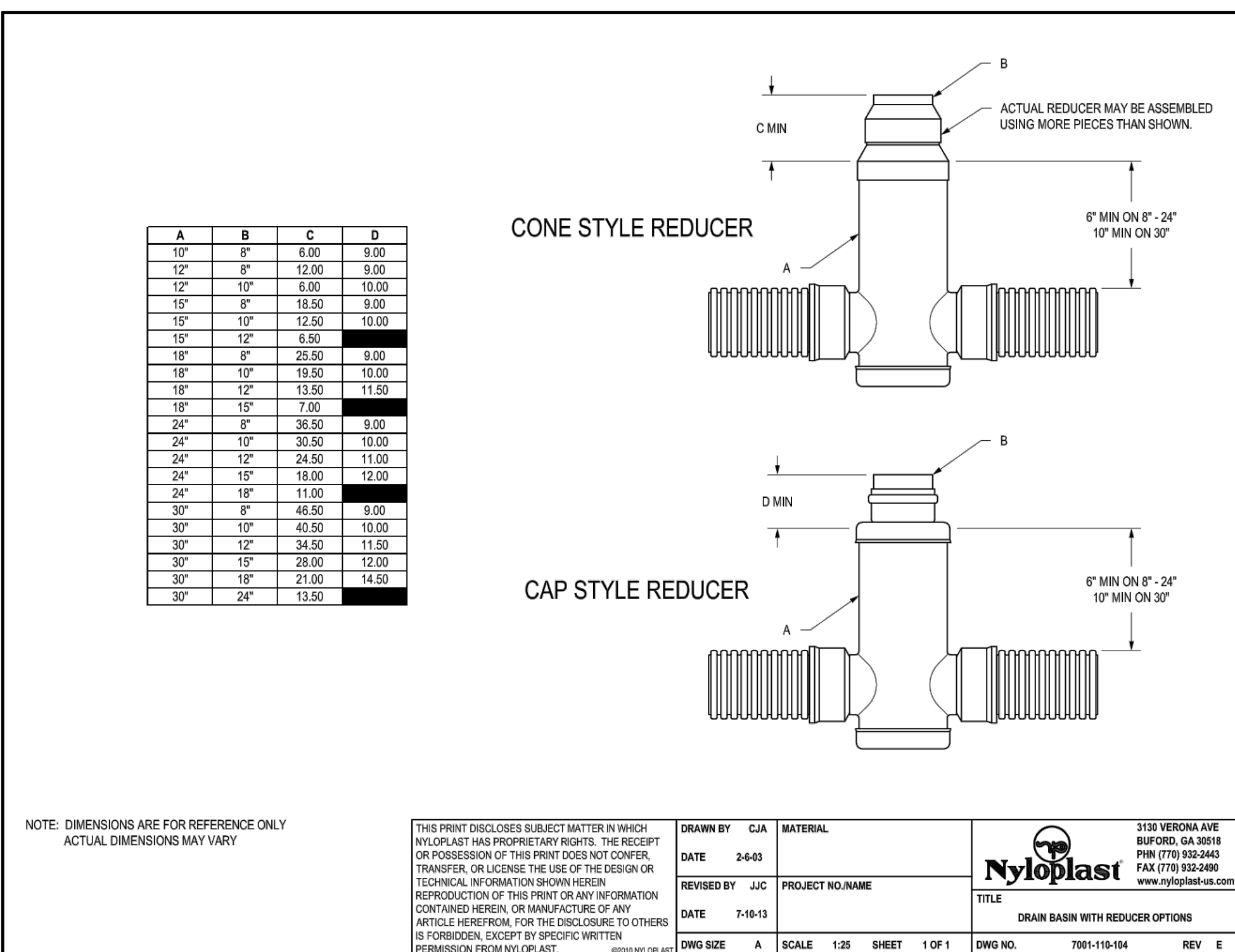

TYPICAL YARD DRAIN/CATCH BASIN

C

REV. NO	DATE	REVISED	DESTROY ALL PRINTS BEARING EARLIER DATE	REV. BY	CKD. BY	APRD BY

THESE DRAWINGS ARE INSTRUMENTS OF SERVICE AND ARE THE PROPERTY OF CANNON. ALL DECISIONS AND INFORMATION ON THESE DRAWINGS ARE FOR USE OF THE SPECIFIED PROJECT AND SHALL NOT BE USED OTHERWISE OR REPRODUCED WITHOUT THE EXPRESSED WRITTEN PERMISSION OF CANNON.

LI RESIDENCE  
GRADING AND DRAINAGE DETAILS  
MERCER ISLAND, WASHINGTON

DRAWN BY SEM	DATE 10/11/2022	CA JOB NO. 220418
CHECKED BY KR	SCALE AS SHOWN	SHEET C4 OF 8







